

## **JA-20.1 Fixed Angle Rotor**



**Used In Beckman Coulter J2, J6,  
and Avanti J Series  
Centrifuges**

## **Trademarks**

Beckman Coulter, the stylized logo, and Avanti, are trademarks of Beckman Coulter, Inc. and are registered in the USPTO.

All other trademarks, service marks, products, or services are trademarks of their respective holders.



## SAFETY NOTICE

This safety notice summarizes information basic to the safe use of the rotor described in this manual. The international symbol displayed above is a reminder to the user that all safety instructions should be read and understood before operation or maintenance of this equipment is attempted. When you see the symbol on other pages throughout this publication, pay special attention to the specific safety information presented. Observance of safety precautions will also help to avoid actions that could damage or adversely affect the performance of the rotor. This rotor was developed, manufactured, and tested for safety and reliability as part of a Beckman Coulter centrifuge/rotor system. Its safety or reliability cannot be assured if used in a centrifuge not of Beckman Coulter's manufacture or in a Beckman Coulter centrifuge that has been modified without Beckman Coulter's approval.



Handle body fluids with care because they can transmit disease. No known test offers complete assurance that such fluids are free of micro-organisms. Some of the most virulent—Hepatitis (B and C) viruses, HIV (I–V), atypical mycobacteria, and certain systemic fungi—further emphasize the need for aerosol protection. Handle other infectious samples according to good laboratory procedures and methods to prevent spread of disease. Because spills may generate aerosols, observe proper safety precautions for aerosol containment. Do not run toxic, pathogenic, or radioactive materials in this rotor without taking appropriate safety precautions. Biosafe containment should be used when Risk Group II materials (as identified in the World Health Organization *Laboratory Biosafety Manual*) are handled; materials of a higher group require more than one level of protection.



The rotor and accessories are not designed for use with materials capable of developing flammable or explosive vapors. Do not centrifuge such materials in nor handle or store them near the centrifuge.



Although rotor components and accessories made by other manufacturers may fit in the JA-20.1 rotor, their safety in this rotor cannot be ascertained by Beckman Coulter. Use of other manufacturers' components or accessories in the JA-20.1 rotor may void the rotor warranty and should be prohibited by your laboratory safety officer. Only the components and accessories listed in this publication should be used in this rotor.



Do not run an empty rotor. Place filled tubes in at least two opposing cavities. Make sure that filled containers are loaded symmetrically into the rotor and that opposing tubes are filled to the same level with liquid of the same density.



If disassembly reveals evidence of leakage, you should assume that some fluid escaped the rotor. Apply appropriate decontamination procedures to the centrifuge and accessories.



Never exceed the maximum rated speed of the rotor and labware in use. Refer to the section on RUN SPEEDS.



Do not use sharp tools on the rotor that could cause scratches in the rotor surface. Corrosion begins in scratches and may open fissures in the rotor with continued use.

## JA-20.1 FIXED ANGLE ROTOR

### SPECIFICATIONS

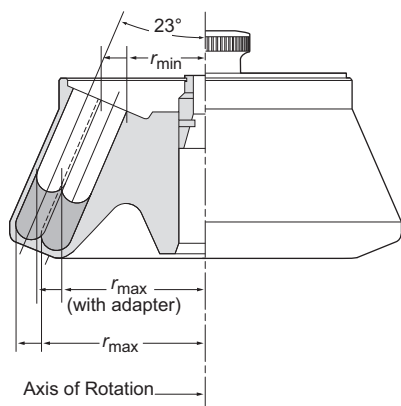

Maximum speed	20 000 rpm*
Critical speed range†	600 to 800 rpm
Density rating at maximum speed	1.2 g/mL
Maximum allowable imbalance of opposing loads	2 grams
Relative Centrifugal Field‡ at maximum speed	
Outer row of tubes	
At $r_{\max}$ (115 mm)	$51\,500 \times g$
At $r_{\max}$ with adapter 342327 (107 mm)	$47\,900 \times g$
At $r_{\min}$ (64 mm)	$28\,700 \times g$
Inner row of tubes	
At $r_{\max}$ (98 mm)	$43\,900 \times g$
At $r_{\max}$ with adapter 342327 (90 mm)	$40\,300 \times g$
At $r_{\min}$ (47 mm)	$21\,100 \times g$
$k$ factors at maximum speed	
Outer row of tubes	371
Outer row of tubes with adapter 342327	325
Inner row of tubes	465
Inner row of tubes with adapter 342327	411
Conditions requiring speed reductions	see RUN SPEEDS
Number of tube cavities	32
Available tubes	see Table 4
Nominal tube dimensions (largest tube)	18 × 99 mm
Nominal tube capacity (largest tube)	15 mL
Nominal rotor capacity	480 mL
Approximate acceleration time to maximum speed	
(rotor fully loaded)	1 1/2 min
Approximate deceleration time from maximum speed	
(rotor fully loaded)	2 1/2 min
Weight of fully loaded rotor	7.5 kg (16.5 lb)
Rotor material	aluminum
Rotor entry code for Avanti J-E, J2 and J6 series	
microprocessor-controlled centrifuges	20.1

\* Maximum speed at 2°C in the Avanti J-E . . . . . 17 000 rpm

† The critical speed range is the range of speeds over which the rotor shifts so as to rotate about its center of mass. Passing through the critical speed range is characterized by some vibration.

‡ Relative Centrifugal Field (RCF) is the ratio of the centrifugal acceleration at a specified radius and speed ( $r\omega^2$ ) to the standard acceleration of gravity ( $g$ ) according to the following formula:

$$\text{RCF} = \frac{r\omega^2}{g}$$

where  $r$  is the radius in millimeters,  $\omega$  is the angular velocity in radians per second ( $2\pi \text{ RPM} / 60$ ), and  $g$  is the standard acceleration of gravity ( $9807 \text{ mm/s}^2$ ). After substitution:

$$\text{RCF} = 1.12 r \left( \frac{\text{RPM}}{1000} \right)^2$$

## DESCRIPTION

*This rotor has been manufactured in an NSAI-registered ISO 9001 or 13485 facility for use with the specified Beckman Coulter centrifuges.*

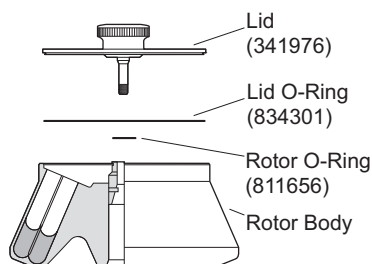

The JA-20.1, rated for 20 000 rpm, is a fixed angle rotor designed to centrifuge up to thirty-two 15-mL tubes in two concentric rows at a 23-degree angle. Used in Beckman Coulter J2 series, J6 series, and Avanti J series centrifuges, the rotor develops centrifugal forces that can efficiently pellet subcellular particles, bacteria, algae, and chloroplasts, or in short-column banding of viruses and subcellular particles. Up to 480 mL of gradient and sample can be centrifuged per run.

A hold-down knob (354456) can be used to secure the rotor to the centrifuge without using the rotor lid. The rotor (with lid attached) has been tested<sup>1</sup> to demonstrate containment of microbiological aerosols under normal conditions of the associated Beckman Coulter centrifuge when used and maintained as instructed.

O-rings made of Buna N rubber in the lid and rotor body maintain atmospheric pressure inside the rotor during centrifugation, if they are properly lubricated. Two pins in the rotor drive hole mate with grooves in the centrifuge drive hub (in older model centrifuges), or with drive hub teeth (new model centrifuges), to prevent the rotor from slipping during acceleration and deceleration.

The JA-20.1 rotor is warranted for 7 years (see the Warranty).

## PREPARATION AND USE

*Specific information about the JA-20.1 rotor is given here. Use the J Series Rotors and Tubes Manual (JR-IM) along with this rotor manual for complete rotor and accessory operation.*

<sup>1</sup> Validation of microbiological containment was done at an independent third-party testing facility (CAMR, Porton Down, UK, or USAMRIID, Ft. Detrick, MD, U.S.A.). Improper use or maintenance may affect seal integrity and thus containment.

**NOTE**

Although rotor components and accessories made by other manufacturers may fit in the JA-20.1 rotor, their safety in this rotor cannot be ascertained by Beckman Coulter. Use of other manufacturers' components or accessories in this rotor may void the rotor warranty and should be prohibited by your laboratory safety officer. Only the components and accessories listed in this publication should be used in this rotor.

**PRERUN SAFETY CHECKS**



*Read the Safety Notice page at the front of this manual before using the rotor.*

1. Make sure that the rotor and lid are clean and show no signs of corrosion or cracking.
2. Check the chemical compatibilities of all materials used (refer to Appendix A in *Rotors and Tubes*).
3. Use only the tubes, bottles, and accessories listed in Table 4.

**ROTOR PREPARATION**

*For runs at other than room temperature, refrigerate or warm the rotor beforehand for fast temperature equilibration.*

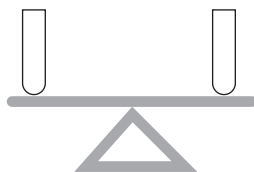

1. Lightly but evenly lubricate metal threads with Spinkote lubricant (306812). Apply a thin film of silicone vacuum grease (335148) to the O-rings.
2. Load the filled containers symmetrically into the rotor. (Refer to TUBES AND BOTTLES on page 13 for information about containers.) If fewer than thirty-two tubes are being run, they must be arranged symmetrically in the rotor (see Figure 1). Opposing tubes must be filled to the same level with liquid of the same density.

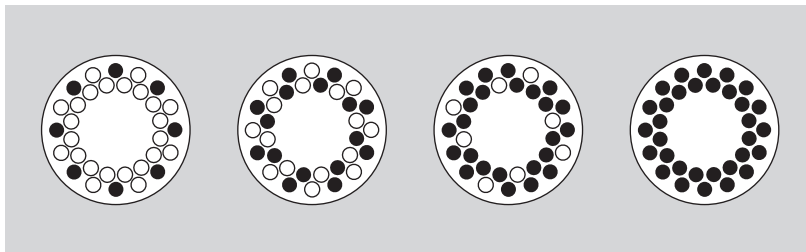

*Figure 1. Arranging Tubes in the Rotor. If fewer than thirty-two tubes are used per run, they can be placed in either row or in a combination of both rows—as long as the loading pattern is symmetrical and weight-balanced.*

## OPERATION

### ROTOR ID

JA-20.1

- For low temperature runs, precool the rotor in the centrifuge or in a refrigerator before use—especially before short runs—to ensure that the rotor reaches the set temperature. A suggested precooling cycle is a minimum of 30 minutes at 2000 rpm at the required temperature.
- If fluid containment is required, *use capped tubes or bottles*. It is strongly recommended that all containers carrying physiological fluids be capped to prevent leakage.
- *J2 and J6 series centrifuges only*. Apply a thin film of Spinkote lubricant (306812) to the centrifuge drive hub before use.
- If you are using an Avanti J series centrifuge, select the JA-20.1 rotor. If you are using a microprocessor-controlled J2 or J6 series centrifuge, enter rotor code **20.1**.

## INSTALLING THE ROTOR

### NOTE

Lubricate J2 and J6 series centrifuge drive hubs with a thin, even coat of Spinkote to prevent the rotor from sticking. Avanti J series centrifuges have Delrin<sup>2</sup> rings on the hubs to prevent sticking, and do not require lubrication.

<sup>2</sup> Delrin is a registered trademark of E. I. Du Pont de Nemours & Company.

Two metal pins inside the rotor drive hole engage with teeth on the centrifuge drive spindle hub to prevent the rotor from slipping during acceleration and deceleration (see Figure 2). When the rotor is properly installed, the pins sit either in the drive hub grooves or on top of the hub surface (see Figure 3).

The rotor pins are positioned parallel to the BECKMAN name engraved at the center of the rotor body (see Figure 4). Knowing the pin orientation before you install the rotor will help to ensure that you position the rotor properly on the hub, minimizing the chance of hub damage. Follow the steps below.

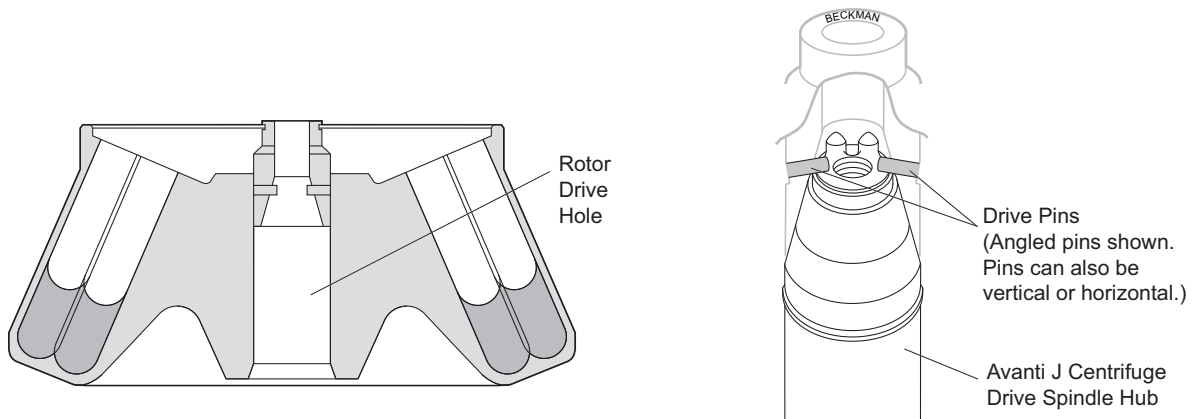

Figure 2. Rotor Drive Pin Location and Orientation

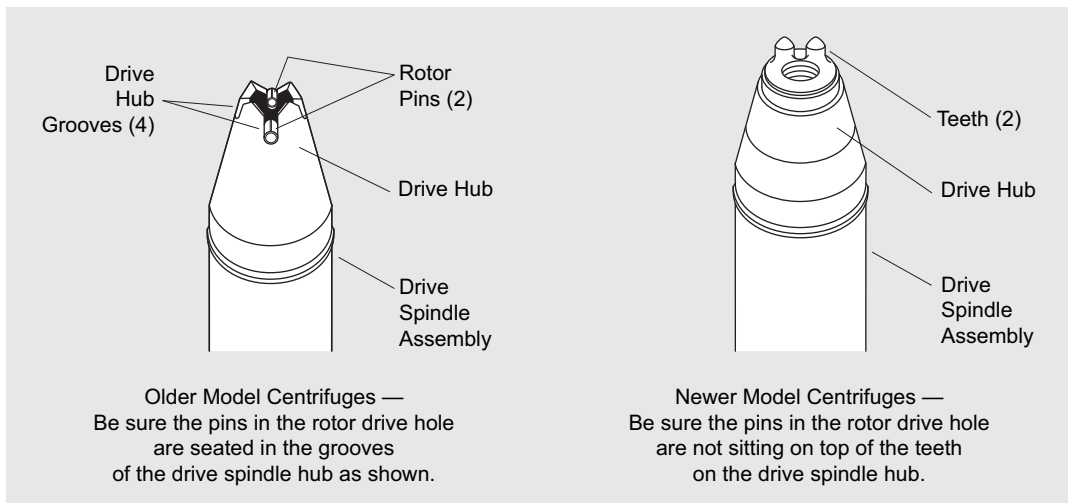

Figure 3. Centrifuge Drive Hub Configurations



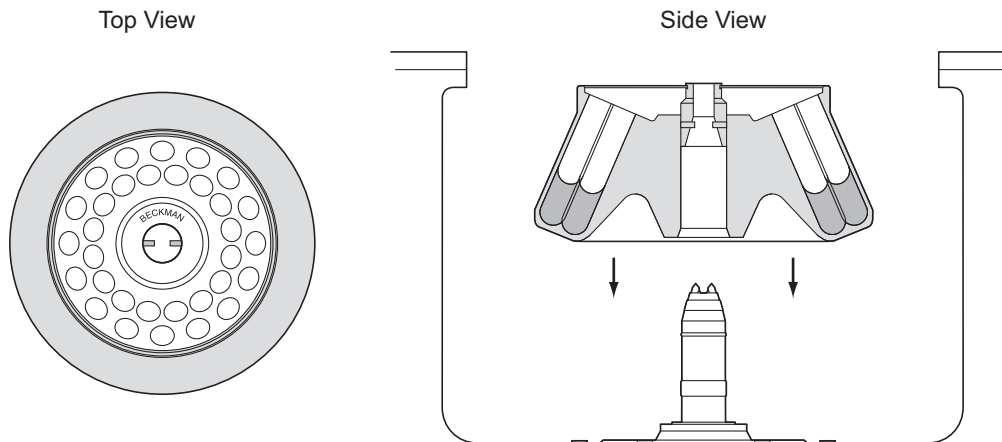
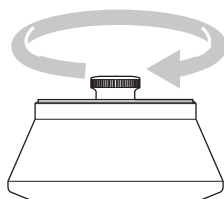
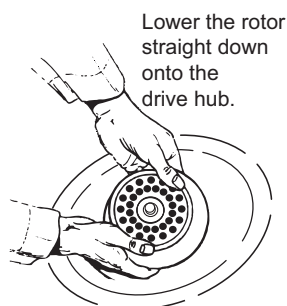

Figure 4. Installing the Rotor



1. Turn the rotor until the BECKMAN name is either horizontal or perpendicular to the drive hub pins or teeth (see Figure 4). Alternately, rotate the drive shaft to align the drive spindle hub pins or teeth with the rotor drive pins.
2. Carefully lower the rotor straight down onto the centrifuge drive spindle hub. *Do not drop the rotor onto the hub.*
3. Slowly turn the rotor, making sure that it is properly seated on the drive spindle hub. (In rare cases, the rotor pins can rest on top of the hub pins or teeth and not seat on the hub surface. This can prevent the rotor from being secured to the drive spindle. Turning the rotor slightly after installing it will move the rotor into proper position.)
4. After the rotor is seated on the hub, place the lid on the rotor. Press down on the lid knob and screw the knob down tight. (Turning the knob to the right attaches the rotor to the hub; the lid remains free and may be slipped on or off while the rotor remains secured in the centrifuge.) If you are using the hold-down knob (354456) and no lid, insert the knob into the rotor drive hole and screw it down tight.

## TEMPERATURE

TEMP °C

4

To ensure that the JA-20.1 rotor reaches the required temperature during the run, follow the appropriate instructions below for the model of centrifuge being used.

## Avanti J Series Centrifuges

---

Enter the run temperature according to the instructions in your centrifuge instruction manual. No additional input is required.

### Microprocessor-Controlled J2 and J6 Series Centrifuges (Models J2-MI, J6-MI, J2-21M, J2-MC, J6-MC, and J2-21 M/E)

---

Enter rotor code **20.1**, then follow the steps below.

1. Press the [TEMP] key on the centrifuge control panel and then use the keypad to enter the sample temperature.
2. Find the compensation value in Table 1 that corresponds with the set temperature and run speed. The compensation values listed in Table 1 are approximates for microprocessor-controlled centrifuges. If precise temperature control is required, determine the compensation settings empirically as follows:
  - a. Fill the rotor with water-filled tubes or bottles. Precool the rotor and water to the required temperature.
  - b. Place the filled, precooled rotor in the centrifuge and run the system for at least 1/2 hour.
  - c. Measure the water temperature. If it is lower than the required run temperature, enter positive compensation units during run setup following steps 3 and 4, below. If it is higher than the required run temperature, enter negative compensation units during run setup, also using steps 3 and 4, below.
  - d. Discard the water. Fill tubes with sample, load tubes into the rotor, and precool the system to the required temperature before starting the run.
3. Press [COMP ADJ]. The word "COMP" flashes below the TEMPERATURE display and the display flashes.
4. Use the keypad to enter the required compensation value. Press the [±.] key to enter a minus sign; pressing it again will remove the minus sign.
5. Check the temperature display. (If the entry is incorrect, press [CE] and reenter the digits.)
6. When the entry is correct, press [ENTER/RECALL].

Table 1. Temperature Compensation Settings for Models J2-HS, J2-MI, and J2-MC Centrifuges. Interpolate if intermediate values are required.

Rotor Speed (rpm)	Required Sample Temperature (°C)						
	-20°	-10°	2°	5°	10°	20°	40°
20 000	N	N	-10	-9	-9	-9	-7
18 000	N	N	-7	-7	-7	-6	-4
15 000	-7	-5	-4	-4	-4	-3	N
10 000	-2	-1	-1	0	0	0	N

An “N” indicates that the rotor cannot achieve the required temperature at this speed.

### NOTE

To clear a COMP ADJ entry, press [COMP ADJ], [0], and [ENTER/RECALL].

## Analog J2 Series Centrifuges

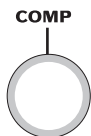
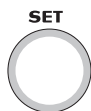

Enter the required run temperature and the appropriate temperature compensation units (see Table 1, 2, or 3) on the centrifuge control panel as follows.

1. Turn the SET knob to the required sample temperature.
2. Find the compensation value (Table 1 for Models J2-HS and J2-21; Table 2 for Model J2-HC; or Table 3 for Models J-21B and J-21C) that corresponds to the required temperature and run speed. Set the COMP dial to that setting. (Interpolate if intermediate values are required.)

## REMOVAL AND SAMPLE RECOVERY



### CAUTION

*If disassembly reveals evidence of leakage, you should assume that some fluid escaped the rotor. Apply appropriate decontamination procedures to the centrifuge and accessories.*

Table 2. Temperature Compensation Settings for the Model J2-HC Centrifuge. Interpolate if intermediate values are required.

Rotor Speed (rpm)	Required Sample Temperature (°C)						
	-20°	-10°	2°	5°	10°	20°	40°
18 000	N	N	-7	-7	-7	-6	-4
15 000	-7	-5	-5	-4	-4	-3	-2
10 000	-4	-2	-1	-1	-1	-1	N

An “N” indicates that the rotor cannot achieve the required temperature at this speed.

Table 3. Temperature Compensation Settings for the J-21B and J-21C Centrifuges. Interpolate if intermediate values are required.

Rotor Speed (rpm)	Required Sample Temperature (°C)			
	2°	5°	10°	20°
20 000	N	9	9	8
18 000	7	7	7	7
14 000	3	3	3	3
8 000	0	0	0	0

An “N” indicates that the rotor cannot achieve the required temperature at this speed.

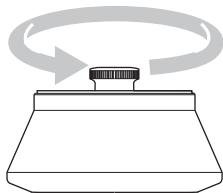

1. Unscrew the rotor lid knob or hold-down knob to release the rotor from the spindle hub.
2. Remove the rotor by lifting it straight up and off the drive spindle. If the rotor sticks to the drive spindle, a collar adapter (338689) and rotor removal tool (338896) may be used.
  - a. Remove the lid and small O-ring from the rotor.
  - b. Slide the flanges of the collar into the empty O-ring groove.
  - c. Screw the larger end of the rotor removal tool into the threaded opening of the collar adapter. As the removal tool tightens down, it pushes against the drive spindle, causing the rotor to rise.

- d. Remove the tool and collar adapter from the rotor by reversing the above procedure.
- e. Replace the O-ring in the groove.
- f. Remove the rotor from the centrifuge.

## TUBES AND BOTTLES

---

The JA-20.1 rotor uses the tubes and bottles listed in Table 4. Be sure to use only those items listed, and to observe the maximum speed limits and fill volumes shown. (Maximum fill volume is the maximum amount that can be centrifuged in the container listed.) Refer to Appendix A in *Rotors and Tubes* for chemical compatibilities of tube, bottle, and accessory materials.

### Temperature Limits

---

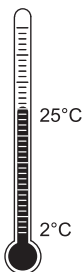

- Plastic containers have been centrifuge tested for use at temperatures between 2 and 25°C. For centrifugation at other temperatures, pretest tubes under anticipated run conditions.
- If plastic containers are frozen before use, make sure that they are thawed to at least 2°C prior to centrifugation.

### Thickwall Tubes

---



Thickwall polypropylene and polycarbonate tubes can be run partially filled (at least half filled) with or without caps, but all opposing tubes for a run must be filled to the same level with liquid of the same density. Do not overfill capless tubes; be sure to note the fill volumes and run speeds shown in Table 4.

Table 4. Available Tubes and Adapters<sup>a</sup> for the JA-20.1 Fixed Angle Rotor.  
Use only the items listed here and observe fill volumes and maximum run speeds.

Tube			Max Fill Vol (mL) <sup>b</sup>	Required Accessory		Max Speed <sup>c</sup> / RCF, <i>k</i> Factor <sup>d</sup> (Outer Row) RCF, <i>k</i> Factor (Inner Row)
Dimensions and Volume	Description	Part Number		Description	Part Number	
18 × 99 mm 15 mL	polycarbonate, thickwall, open-top	342080 <sup>e</sup>	12.5	none	—	20 000 rpm 51 500 × <i>g</i> , 371 43 900 × <i>g</i> , 465
18 × 97 mm 15 mL	polyethylene, thickwall, open-top	342081 <sup>e</sup>	12.5	none	—	20 000 rpm 51 500 × <i>g</i> , 371 43 900 × <i>g</i> , 465
18 × 98 mm 15 mL	polypropylene, thick-wall, open-top	342082 <sup>e</sup>	12.5	none	—	20 000 rpm 51 500 × <i>g</i> , 371 43 900 × <i>g</i> , 465
16 × 76 mm 10 mL	polypropylene, thickwall, open-top	355640	8	adapter	342327	20 000 rpm 47 900 × <i>g</i> , 325 40 300 × <i>g</i> , 411
16 × 80 mm 10 mL	polycarbonate bottle w/screw cap	355672	8	adapter	342327	20 000 rpm 47 900 × <i>g</i> , 325 40 300 × <i>g</i> , 411
16 × 76 mm 10 mL	polycarbonate thick-wall, open-top	355630	8	adapter	342327	20 000 rpm 47 900 × <i>g</i> , 325 40 300 × <i>g</i> , 411
12 × 75 mm 5 mL	glass tube <sup>f</sup>	f	f	adapter	356971 (Delrin)	f
13 × 99 mm 7 mL	glass tube <sup>f</sup>	f	f	adapter	356977 (Delrin)	f

<sup>a</sup> Adapters listed in this table hold one tube each.

<sup>b</sup> Above 20°C fill polypropylene tubes at least half full.

<sup>c</sup> Maximum speeds listed are guidelines only. These speeds have been achieved in reliability tests at Beckman Coulter, but, because of manufacturing variances, no guarantee of performance or fit is expressed or implied.

<sup>d</sup> *k* factors are calculated for full tubes and will be different for partially filled tubes. See RUN TIMES for information on calculating *k* factors.

<sup>e</sup> To order caps for 15-mL tubes 342080, 342081, and 342082, use part number 343656 for a package of 50. Cap 343656 is made of Hytrel thermoplastic polyester elastomer. Hytrel is a registered trademark of E. I. Du Pont de Nemours & Company. Note that Hytrel does not provide the same chemical resistance as the tube materials. Before using the caps, check with the manufacturer to verify Hytrel's ability to withstand exposure to the chemicals you will be using.

<sup>f</sup> Commercially available. Observe manufacturer's speed and fill volume guidelines.

Continued—

Table 4. Available Tubes and Adapters<sup>a</sup> for the JA-20.1 Fixed Angle Rotor (continued)

Tube			Max Fill Vol (mL) <sup>b</sup>	Required Accessory		Max Speed <sup>c</sup> / RCF, <i>k</i> Factor <sup>d</sup> (Outer Row) RCF, <i>k</i> Factor (Inner Row)
Dimensions and Volume	Description	Part Number		Description	Part Number	
16 × 99 mm 15 mL	glass tube <sup>f</sup>	f	f	adapter assembly	adapter 342348 (polyethylene) used with pad 342644 (neoprene)	f
12 × 75 mm 3 mL	glass tube <sup>f</sup>	f	f	adapter	342329 (polypropylene)	f
10 × 75 mm 3 mL	glass tube <sup>f</sup>	f	f	adapter	342329	f

<sup>a</sup> Adapters listed in this table hold one tube each.

<sup>b</sup> Above 20°C fill polypropylene tubes at least half full.

<sup>c</sup> Maximum speeds listed are guidelines only. These speeds have been achieved in reliability tests at Beckman Coulter, but, because of manufacturing variances, no guarantee of performance or fit is expressed or implied.

<sup>d</sup> *k* factors are calculated for full tubes and will be different for partially filled tubes. See RUN TIMES for information on calculating *k* factors.

<sup>e</sup> To order caps for 15-mL tubes 342080, 342081, and 342082, use part number 343656 for a package of 50. Cap 343656 is made of Hytrel thermoplastic polyester elastomer. Hytrel is a registered trademark of E. I. Du Pont de Nemours & Company. Note that Hytrel does not provide the same chemical resistance as the tube materials. Before using the caps, check with the manufacturer to verify Hytrel's ability to withstand exposure to the chemicals you will be using.

<sup>f</sup> Commercially available. Observe manufacturer's speed and fill volume guidelines.



### Polycarbonate and Polypropylene Bottles

Capped polycarbonate and polypropylene bottles may be run completely filled, or partially filled (not less than half full). All opposing containers for a run must be filled to the same level. Be sure to note the reductions in run speed shown in Table 4 if bottles are partially filled.

### RUN TIMES

The *k* factor of the rotor is a measure of the rotor's pelleting efficiency. Beckman Coulter has calculated the *k* factors for all of

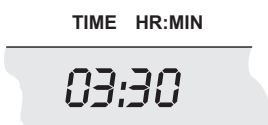

its rotors, at maximum speed with full tubes, using the following formula:

$$k = \frac{\ln(r_{\max}/r_{\min})}{\omega^2} \times \frac{10^{13}}{3600} \quad (1)$$

where  $\omega$  is the angular velocity of the rotor in radians per second ( $\omega = 0.105 \times \text{rpm}$ ),  $r_{\max}$  is the maximum radius, and  $r_{\min}$  is the minimum radius.

After substitution:

$$k = \frac{(2.533 \times 10^{11}) \ln(r_{\max}/r_{\min})}{\text{rpm}^2} \quad (2)$$

In the JA-20.1 rotor, the  $k$  factor is 371 for full 15-mL tubes placed in the outer row, and 465 for full 15-mL tubes placed in the inner row. For containers that nominally hold less than 15 mL, the  $k$  factors will be different. Calculate  $k$  factors for these containers using equation 2.

Use the  $k$  factor in the following equation to estimate the run time  $t$  (in hours) required to pellet particles of known sedimentation coefficient  $s$  (in Svedberg units,  $S$ ).

$$t = \frac{k}{s} \quad (3)$$

For example, at 20 000 rpm, mammalian viruses ( $s = 700 S$ ) can be pelleted in

$$t = \frac{374}{700} \approx 1/2 \text{ hour} \quad (4)$$

Run times can be estimated for centrifugation at less than maximum speed by adjusting the  $k$  factor as follows:

$$k_{\text{adj}} = k \left( \frac{20\,000}{\text{actual run speed}} \right)^2 \quad (5)$$

Run times can also be estimated from data established in prior experiments using a different rotor if the  $k$  factor of the previous rotor is known. For any two rotors, a and b,



$$\frac{t_a}{t_b} = \frac{k_a}{k_b} \quad (6)$$

For more information on  $k$  factors, see *Use of  $k$  Factor for Estimating Run Times from Previously Established Run Conditions* (publication DS-719).

## RUN SPEEDS

---



The centrifugal force at a given radius in a rotor is a function of speed. Comparisons of forces between different rotors are made by comparing the rotors' relative centrifugal fields (RCF). When rotational speed is adjusted so that identical samples are subjected to the same RCF in two different rotors, the samples are subjected to the same force. The RCF at a number of rotor speeds is provided in Table 5.

**Do not select rotational speeds higher than the maximums you have determined to be appropriate for your protocols (in no case above 20 000 rpm or the limit shown in Table 4).** In addition, when centrifuging solutions more dense than 1.2 g/mL in this rotor, calculate the reduced maximum allowable rotor speed:

$$\text{reduced maximum speed} = (20\,000 \text{ rpm}) \sqrt{\frac{1.2 \text{ g/mL}}{\text{density of tube contents}}} \quad (7)$$

## CARE AND MAINTENANCE

### MAINTENANCE

---

#### NOTE

Do not use sharp tools on the rotor that could cause scratches in the rotor surface. Corrosion begins in scratches and may open fissures in the rotor with continued use.

- Periodically (at least monthly) inspect the rotor, especially inside cavities, for rough spots or pitting, white powder deposits

JA-20.1 Rotor

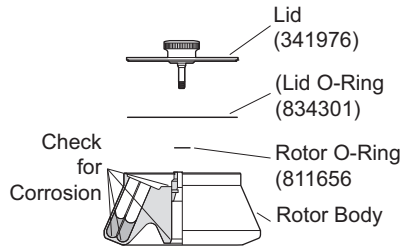

(frequently aluminum oxide), or heavy discoloration. If any of these signs are evident, do not run the rotor. Contact your Beckman Coulter representative for information about the Field Rotor Inspection Program and the rotor repair center.

Table 5. Relative Centrifugal Fields for the JA-20.1 Rotor.  
 Entries in this table are calculated from the formula  $RCF = 1.12 r (RPM/1000)^2$   
 and then rounded to three significant digits.

Rotor Speed (rpm)	Outer Row Relative Centrifugal Field ( $\times g$ )			Rotor Speed (rpm)	Inner Row Relative Centrifugal Field ( $\times g$ )		
	At $r_{max}$ (115 mm)	at $r_{max}^*$ (107 mm)	At $r_{min}$ (64 mm)		At $r_{max}$ (98 mm)	At $r_{max}^*$ (90 mm)	At $r_{min}$ (47 mm)
20 000	51 500	47 900	28 700	20 000	43 900	40 300	21 100
18 000	41 700	38 800	23 200	18 000	18 000	32 700	17 100
16 000	33 000	30 700	18 400	16 000	28 100	25 800	13 500
14 000	25 200	23 500	14 000	14 000	21 500	19 800	10 300
12 000	18 500	17 300	10 300	12 000	15 800	14 500	7 580
10 000	12 900	12 000	7 170	10 000	11 000	9 100	5 260
8 000	8 240	7 670	4 590	8 000	7 020	7 670	3 370
6 000	5 440	4 310	2 580	6 000	3 950	3 630	1 900
4 000	2 060	1 920	1 150	4 000	1 760	1 760	842

\*With adapter 342327

Relative Centrifugal Fields for the JA-20.1 Rotor

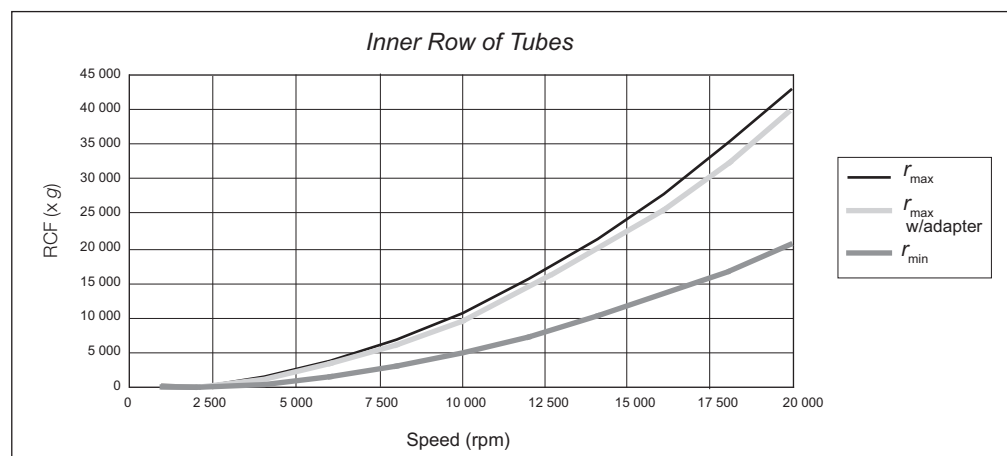
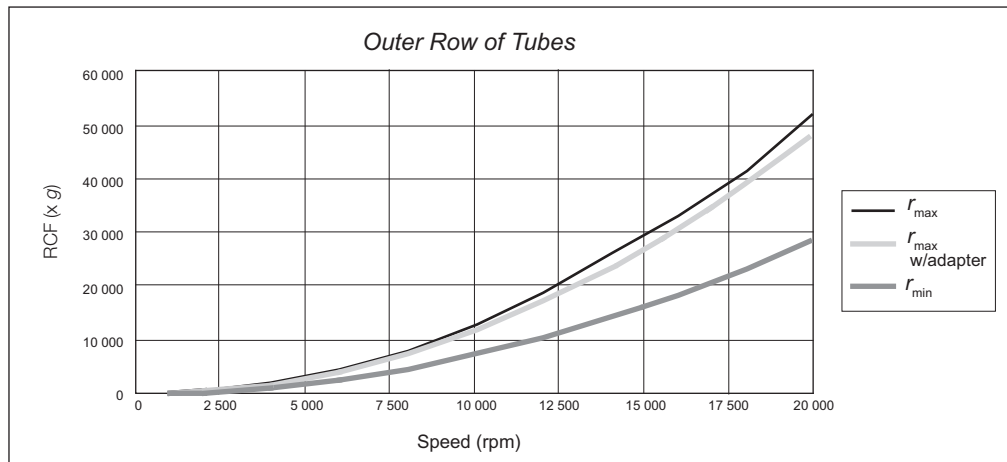

- Before using the rotor, inspect the rotor drive pins to ensure that they are not damaged. Damaged drive pins can prevent the rotor from seating properly on the centrifuge drive hub (Avanti J series centrifuges only). To inspect the drive pins, turn the rotor upside down and look into the drive hold in the center of the rotor. If the drive pins appear damaged, contact Beckman Coulter Field Service.
- Regularly lubricate the metal threads in the rotor with a thin, even coat of Spinkote lubricant (306812). Failure to keep these threads lubricated can result in damaged threads.
- Regularly apply silicone vacuum grease (335148) to the O-rings. Replace O-rings about twice a year or whenever worn or damaged.
- Routinely apply Spinkote lubricant (306812) to the centrifuge drive spindle hub to prevent the rotor from sticking (not required on Avanti J series centrifuges).

Refer to Appendix A in *Rotors and Tubes* for chemical compatibilities of rotor and accessory materials. Your Beckman Coulter representative provides contact with the Field Rotor Inspection Program and the rotor repair center.

## CLEANING

*Wash the rotor and rotor components immediately if salts or other corrosive materials are used or if spillage has occurred. Do not allow corrosive materials to dry on the rotor.*

Under normal use, wash the rotor frequently (at least weekly) to prevent buildup of residues.



1. Remove the O-rings before washing.
2. Wash the rotor and lid in a mild detergent, such as Beckman Solution 555 (339555), that won't damage the rotor. The Rotor Cleaning Kit (339558) contains two special plastic-coated brushes and two quarts of Solution 555 for use with rotors and accessories. Dilute the detergent 10 to 1 with water.

### NOTE

Do not wash rotor components in a dishwasher.  
Do not soak in detergent solution for long periods, such as overnight.

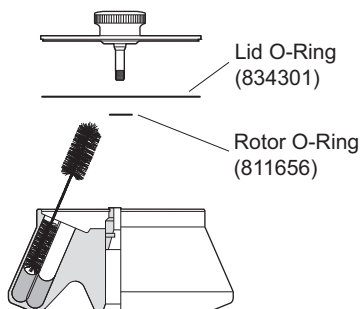

3. Thoroughly rinse the cleaned rotor and components with distilled water.
4. Air-dry the rotor and lid upside down. *Do not use acetone to dry the rotor.*
5. Apply a thin, even coat of silicone vacuum grease to the lid O-ring before replacing it in the groove in the outer rim of the lid. Also apply silicone vacuum grease to the rotor O-ring before reassembly.

Clean metal threads every 6 months, or as necessary. Use a brush and concentrated Solution 555. Rinse and dry thoroughly, then lubricate lightly but evenly with Spinkote to coat all threads.

Periodically remove the O-rings and wipe clean as necessary. Clean the O-ring grooves with a cotton-tipped swab. Reapply a light film of silicone vacuum grease.

## DECONTAMINATION

---



If the rotor (and/or accessories) becomes contaminated with radioactive material, it should be decontaminated using a solution that will not damage the anodized surfaces. Beckman Coulter has tested a number of solutions and found two that do not harm anodized aluminum: RadCon Surface Spray or IsoClean Solution (for soaking),<sup>3</sup> and Radiacwash.<sup>4</sup>

### NOTE

IsoClean can cause fading of colored anodized surfaces. Use it only when necessary and remove it promptly from surfaces.

While Beckman Coulter has tested these methods and found that they do not damage components, no guarantee of decontamination is expressed or implied. Consult your laboratory safety officer regarding the proper decontamination methods to use.



If the rotor or other components are contaminated with toxic or pathogenic materials, follow appropriate decontamination procedures as outlined by your laboratory safety officer.

## STERILIZATION AND DISINFECTION

---

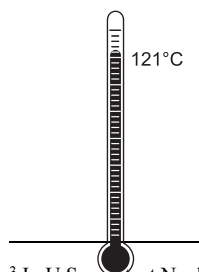

- The rotor and all rotor components can be autoclaved at 121°C for up to an hour. Remove the lid from the rotor and place the rotor and lid in the autoclave upside down.
- Ethanol (70%)<sup>5</sup> may be used on all rotor components, including those made of plastic. Bleach (sodium hypochlorite) may be used,

<sup>3</sup> In U.S., contact Nuclear Associates (New York); in Eastern Europe and Commonwealth States, contact Victoreen GmbH (Munich); in South Pacific, contact Gammasonics Pty. Ltd. (Australia); in Japan, contact Toyo Medic Co. Ltd. (Tokyo).

<sup>4</sup> In U.S., contact Biodex Medical Systems (Shirley, New York); internationally, contact the U.S. office to find the dealer closest to you.

<sup>5</sup> Flammability hazard. Do not use in or near operating centrifuges.

but may cause discoloration of anodized surfaces. Use the minimum immersion time for each solution, per laboratory standards.

While Beckman Coulter has tested these methods and found that they do not damage the rotor or components, no guarantee of sterility or disinfection is expressed or implied. When sterilization or disinfection is a concern, consult your laboratory safety officer regarding proper methods to use.

Refer to publication IN-192, included in each box of tubes or bottles, for tube and bottle sterilization and disinfection procedures.

## **STORAGE**

---

When the rotor is not in use, store it in a dry environment (not in the instrument) with the lid removed to allow air circulation so moisture will not collect in the tube cavities.

## RETURNING A ROTOR

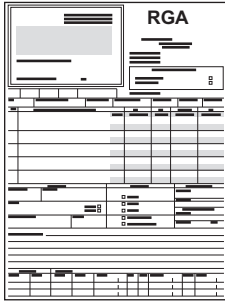

Before returning a rotor or accessory for any reason, prior permission (a Returned Goods Authorization form) must be obtained from Beckman Coulter, Inc. This RGA form may be obtained from your local Beckman Coulter sales office, and should contain the following information:

- serial number
- history of use (approximate frequency of use),
- reason for the return,
- original purchase order number, billing number, and shipping number, if possible,
- name and phone number of the person to be notified upon receipt of the rotor or accessory at the factory, and,
- name and phone number of the person to be notified about repair costs, etc.

To protect our personnel, it is the customer's responsibility to ensure that all parts are free from pathogens and/or radioactivity. Sterilization and decontamination must be done before returning the parts. Smaller items (such as tubes, bottles, etc.) should be enclosed in a sealed plastic bag.

*All parts must be accompanied by a note, plainly visible on the outside of the box or bag, stating that they are safe to handle and that they are not contaminated with pathogens or radioactivity. **Failure to attach this notification will result in return or disposal of the items without review of the reported problem.***

Use the address label printed on the RGA form when mailing the rotor and/or accessories.

Customers located outside the United States should contact their local Beckman Coulter office.



## SUPPLY LIST

### NOTE

Publications referenced in this manual can be obtained by calling Beckman Coulter at 1-800-742-2345 in the United States, or by contacting your local Beckman Coulter office.

For detailed information on ordering parts and supplies, contact Beckman Coulter Sales (1-800-742-2345 in the United States) or your local Beckman Coulter office, or see the Beckman Coulter *High Performance, High Speed, High Capacity Rotors, Tubes, and Accessories* catalog (BR-8102, available at [www.beckmancoulter.com](http://www.beckmancoulter.com)). For your convenience, a partial list is given below.

## REPLACEMENT ROTOR PARTS

JA-20.1 rotor assembly . . . . .	342095
Tie-Down Kit . . . . .	364915
Lid attachment bolt assembly . . . . .	358368
O-ring for rotor body . . . . .	811656
O-ring for rotor lid . . . . .	834301

## SUPPLIES

Tubes, bottles, and adapters . . . . .	see Table 4
Spinkote lubricant (2 oz) . . . . .	306812
Silicone vacuum grease (1 oz) . . . . .	335148
Rotor Cleaning Kit . . . . .	339558
Beckman Solution 555 (1 qt) . . . . .	339555
Rotor cleaning brush . . . . .	339379
Rotor lifting handle and removal tool . . . . .	338896
Adapter collar for rotor removal tool 338896 . . . . .	338689
Hold-down knob (for use without lid in J2/J6 series centrifuges only) . . . . .	392889
Caps (box of 50) for tubes 342080, 342081, and 342082 . . . . .	343656



---

## J SERIES ROTOR WARRANTY

Subject to the conditions specified below and the warranty clause of the Beckman Coulter, Inc., terms and conditions of sale in effect at the time of sale, Beckman Coulter, Inc. agrees to correct either by repair, or, at its election, by replacement, any defects of material or workmanship which develop within seven (7) years after delivery of a J series rotor to the original buyer by Beckman Coulter, Inc. or by an authorized representative, provided that investigation and factory inspection by Beckman Coulter, Inc. discloses that such defect developed under normal and proper use. Should a Beckman Coulter centrifuge be damaged due to a failure of a rotor covered by this warranty, Beckman Coulter will supply free of charge all centrifuge parts required for repair.

### REPLACEMENT

Any product claimed to be defective must, if requested by Beckman Coulter, Inc., be returned to the factory, transportation charges prepaid, and will be returned to Buyer with the transportation charges collect unless the product is found to be defective, in which case Beckman Coulter, Inc. will pay all transportation charges.

A defective rotor will be replaced by Beckman Coulter, Inc. at its then current list price less a credit based upon the age of the rotor (years since date of purchase). The Buyer shall not receive credit until the claimed defective rotor is returned to Beckman Coulter's Indianapolis, Indiana facility or delivered to a Beckman Field Service representative.

The replacement price (cost to Buyer) for the respective rotor shall be calculated as follows:

$$\text{Replacement price} = \text{Current rotor list price} \times \frac{\text{years}}{7}$$

### CONDITIONS

1. Except as otherwise specifically provided herein, this warranty covers the rotor only and Beckman Coulter, Inc. shall not be liable for damage to accessories or ancillary supplies including but not limited to (i) tubes, (ii) tube caps, (iii) tube adapters, or (iv) tube contents.
2. This warranty is void if the rotor has been subjected to customer misuse such as operation or maintenance contrary to the instructions in the Beckman Coulter rotor or centrifuge manual.
3. This warranty is void if the rotor is operated with a rotor drive unit or in a centrifuge unmatched to the rotor characteristics, or is operated in a Beckman Coulter centrifuge that has been improperly disassembled, repaired, or modified.

### DISCLAIMER

IT IS EXPRESSLY AGREED THAT THE ABOVE WARRANTY SHALL BE IN LIEU OF ALL WARRANTIES OF FITNESS AND OF THE WARRANTY OF MERCHANTABILITY AND THAT BECKMAN COULTER, INC. SHALL HAVE NO LIABILITY FOR SPECIAL OR CONSEQUENTIAL DAMAGES OF ANY KIND WHATSOEVER ARISING OUT OF THE MANUFACTURE, USE, SALE, HANDLING, REPAIR, MAINTENANCE, OR REPLACEMENT OF THE PRODUCT.

---



Beckman Coulter, Inc. • 250 S. Kraemer Blvd. • Brea, California 92821 U.S.A.  
Sales and Service: 1-800-742-2345 • Internet: [www.beckmancoulter.com](http://www.beckmancoulter.com) • Printed in U.S.A.

© 2014 Beckman Coulter, Inc.  
All rights reserved