

JA-18 Fixed Angle Rotor



**Used In Beckman Coulter J2, J6,
and Avanti J Series Centrifuges**

Trademarks

Beckman Coulter, the stylized logo, Avanti, and Quick-Seal are trademarks of Beckman Coulter, Inc. and are registered in the USPTO.

All other trademarks, service marks, products, or services are trademarks of their respective holders.



SAFETY NOTICE

This safety notice summarizes information basic to the safe use of the rotor described in this manual. The international symbol displayed above is a reminder to the user that all safety instructions should be read and understood before operation or maintenance of this equipment is attempted. When you see the symbol on other pages throughout this publication, pay special attention to the specific safety information presented. Observance of safety precautions will also help to avoid actions that could damage or adversely affect the performance of the rotor. This rotor was developed, manufactured, and tested for safety and reliability as part of a Beckman Coulter centrifuge/rotor system. Its safety or reliability cannot be assured if used in a centrifuge not of Beckman Coulter's manufacture or in a Beckman Coulter centrifuge that has been modified without Beckman Coulter's approval.



Handle body fluids with care because they can transmit disease. No known test offers complete assurance that such fluids are free of micro-organisms. Some of the most virulent—Hepatitis (B and C) viruses, HIV (I–V), atypical mycobacteria, and certain systemic fungi—further emphasize the need for aerosol protection. Handle other infectious samples according to good laboratory procedures and methods to prevent spread of disease. Because spills may generate aerosols, observe proper safety precautions for aerosol containment. Do not run toxic, pathogenic, or radioactive materials in this rotor without taking appropriate safety precautions. Biosafe containment should be used when Risk Group II materials (as identified in the World Health Organization *Laboratory Biosafety Manual*) are handled; materials of a higher group require more than one level of protection.



The rotor and accessories are not designed for use with materials capable of developing flammable or explosive vapors. Do not centrifuge such materials in nor handle or store them near the centrifuge.



Although rotor components and accessories made by other manufacturers may fit in the JA-18 rotor, their safety in this rotor cannot be ascertained by Beckman Coulter. Use of other manufacturers' components or accessories in the JA-18 rotor may void the rotor warranty and should be prohibited by your laboratory safety officer. Only the components and accessories listed in this publication should be used in this rotor.



Do not run an empty rotor. Place filled tubes in at least two opposing cavities. Make sure that filled containers are loaded symmetrically into the rotor and that opposing tubes are filled to the same level with liquid of the same density.



If disassembly reveals evidence of leakage, and pathogenic or radioactive materials are involved, you should assume that some fluid escaped the rotor. Apply appropriate decontamination procedures to the centrifuge and accessories.



Never exceed the maximum rated speed of the rotor and labware in use. Refer to the section on RUN SPEEDS.



Do not use sharp tools on the rotor that could cause scratches in the rotor surface. Corrosion begins in scratches and may open fissures in the rotor with continued use.

JA-18 FIXED ANGLE ROTOR

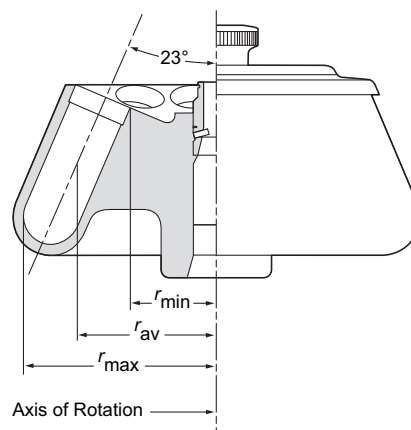

SPECIFICATIONS

| | |
|--|--------------------|
| Maximum speed | 18 000 rpm |
| Critical speed range* | 600 to 800 rpm |
| Maximum solution density | 1.2 g/mL |
| Maximum allowable imbalance of opposing loads | 2 grams |
| Relative Centrifugal Field† at maximum speed | |
| At r_{\max} (132 mm) | $47\,900 \times g$ |
| At r_{av} (98 mm) | $35\,600 \times g$ |
| At r_{\min} (64 mm) | $23\,200 \times g$ |
| k factor at maximum speed | 566 |
| Number of tube cavities | 10 |
| Available tubes and bottles | see Table 1 |
| Nominal dimensions of largest tube | 38 × 102 mm |
| Nominal tube capacity | 100 mL |
| Nominal rotor capacity | 1 L |
| Approximate acceleration time to maximum speed (rotor fully loaded) | 6.5 min |
| Approximate deceleration time from maximum speed (rotor fully loaded, max. brake) | 5 min |
| Weight of fully loaded rotor | 12 kg (26 lb) |
| Rotor material | aluminum |
| Conditions requiring speed reduction | see RUN SPEEDS |
| Rotor entry code | 18 |

* The critical speed range is the range of speeds over which the rotor shifts so as to rotate about its center of mass. Passing through the critical speed range is characterized by some vibration.

† Relative Centrifugal Field (RCF) is the ratio of the centrifugal acceleration at a specified radius and speed ($r\omega^2$) to the standard acceleration of gravity (g) according to the following formula:

$$\text{RCF} = \frac{r\omega^2}{g}$$

where r is the radius in millimeters, ω is the angular velocity in radians per second ($2\pi \text{ RPM}/60$), and g is the standard acceleration of gravity (9807 mm/s^2). After substitution:

$$\text{RCF} = 1.12 r \left(\frac{\text{RPM}}{1000} \right)^2$$

DESCRIPTION

This rotor has been manufactured in a registered ISO 9001 or 13485 facility for use with the specified Beckman Coulter centrifuges.

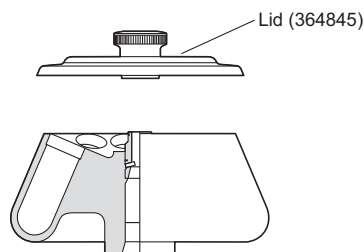

The JA-18 fixed angle rotor, rated for 18 000 rpm, is designed to centrifuge up to ten 100-mL containers at a 23-degree angle to the axis of rotation. Used in Beckman Coulter J2, J6, and Avanti J series centrifuges, the rotor develops centrifugal forces that can efficiently pellet cells, cellular organelles, and membrane fragments.

The rotor body and lid are made of aluminum and are anodized for corrosion resistance—the rotor is black and the lid is blue.

Pins in the rotor drive hole mate with grooves in the centrifuge drive hub (older model centrifuges), or with drive hub teeth (new model centrifuges), to prevent the rotor from slipping during acceleration and deceleration.

Starting in 2002, JA-18 rotors are manufactured with magnets embedded in the rotor base for rotor identification in the Avanti J-E centrifuge. Older JA-18 rotors without magnets can be used in the Avanti J-E, but the rotor speed will be limited to 14 000 rpm. (Other Avanti J series and J2 series centrifuges use alternate methods of rotor identification that enable the rotor to run up to 18 000 rpm.)

The rotor has been tested¹ to demonstrate containment of microbiological aerosols under normal operating conditions of the associated Beckman Coulter centrifuge, when used and maintained as instructed.

The JA-18 rotor is warranted for 7 years (see the Warranty).

PREPARATION AND USE

Specific information about the JA-18 rotor is given here. Use the J Series Rotors and Tubes manual (JR-IM) along with this rotor manual for complete rotor and accessory operation.

¹ Validation of microbiological containment was done at an independent third-party testing facility (CAMR, Porton Down, UK, or USAMRIID, Ft. Detrick, MD, U.S.A.). Improper use or maintenance may affect seal integrity and thus containment.

NOTE

Although rotor components and accessories made by other manufacturers may fit in the JA-18 rotor, their safety in this rotor cannot be ascertained by Beckman Coulter. Use of other manufacturers' components or accessories in this rotor may void the rotor warranty and should be prohibited by your laboratory safety officer. Only the components and accessories listed in this publication should be used in this rotor.

PRERUN SAFETY CHECKS



Read the Safety Notice page at the front of this manual before using the rotor.

1. Make sure that the rotor and lid are clean and show no signs of corrosion or cracking.
2. Check the chemical compatibilities of all materials used (refer to Appendix A in *Rotors and Tubes*).
3. Verify that the tubes and bottles being used are listed in Table 1.

ROTOR PREPARATION

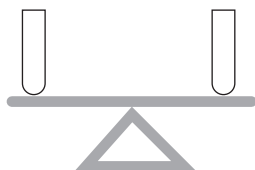

For runs at other than room temperature, refrigerate or warm the rotor beforehand for fast temperature equilibration.

Load the filled containers symmetrically into the rotor. (Refer to TUBES AND BOTTLES on page 7 for information about containers.) If fewer than ten tubes are being run, they must be arranged symmetrically in the rotor (see Figure 1). Opposing tubes must be filled to the same level with liquid of the same density (within 2 grams).

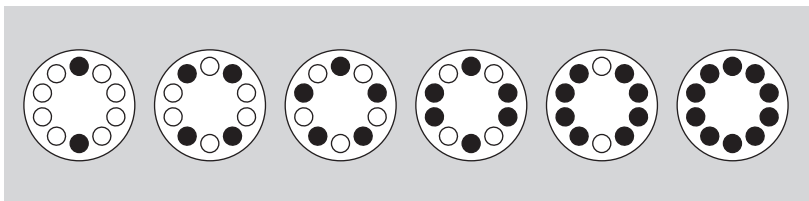

Figure 1. Arranging Tubes or Bottles in the Rotor. Two, four, five, six, eight, or ten tubes or bottles can be run, if they are arranged symmetrically in the rotor, as shown.

TUBES AND BOTTLES

The JA-18 rotor uses the tubes and bottles listed in Table 1. Use only those items listed, and observe the maximum speed limits and fill volumes shown. (Maximum fill volume is the maximum amount that can be centrifuged in the container listed.) Refer to Appendix A in *Rotors and Tubes* for chemical compatibilities of tube, bottle, and accessory materials.

Some conical tubes or bottles from other manufacturers may be used in this rotor with adapters. Because Beckman Coulter cannot test all manufacturers' tubes or bottles with respect to their ability to withstand the *g*-forces generated by this rotor, it is highly recommended that you pretest any other manufacturer's tubes in these adapters using water instead of valuable samples.



CAUTION

- *Some tube/adaptor combinations (15-mL and 50-mL conical tubes with adapters 356592 and 356593; see Table 1) are too tall to allow the lid to seat properly on the rotor, so the lid cannot be used when these tubes are run. In Avanti J series centrifuges the lid must be used during each run, so these tube/adaptor combinations cannot be run in an Avanti J. In J2 and J6 series centrifuges the rotor can be run without the lid; however, the rotor may not reach top speed and temperature control may also be impaired.*
 - *Do not run 50-mL tubes with snap-on caps in this rotor. The *g*-forces generated during operation may cause the snap-on caps to come off, which could dislodge the rotor lid.*
-

Temperature Limits

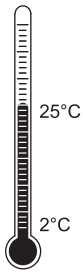

- Plastic containers have been centrifuge tested for use at temperatures between 2 and 25°C. For centrifugation at other temperatures, pretest tubes under anticipated run conditions.
- If plastic containers are frozen before use, make sure that they are thawed to at least 2°C prior to centrifugation.

Thickwall Tubes



Thickwall polypropylene and polycarbonate tubes can be run partially filled (not less than half full) with or without caps, but all opposing tubes for a run must be filled to the same level with liquid of the same density. Do not overfill capless tubes; be sure to note the fill volumes and run speeds shown in Table 1.



Polycarbonate and Polypropylene Bottles

Capped polycarbonate and polypropylene bottles may be run completely filled, or partially filled (not less than half full). All opposing containers for a run must be filled to the same level with liquid of the same density. Be sure to note the fill volumes and run speeds shown in Table 1.

OPERATION

ROTOR ID

JA-18

- For low-temperature runs, precool the rotor in the centrifuge or in a refrigerator before use—especially before short runs—to ensure that the rotor reaches the set temperature. A suggested precooling cycle is a minimum of 30 minutes at 2000 rpm at the required temperature.
- If fluid containment is required, *use capped tubes or bottles*. It is strongly recommended that all containers carrying physiological fluids be capped to prevent leakage.

Table 1. Available Tubes and Bottles for the JA-18 Fixed Angle Rotor.
Use only the items listed here and observe fill volumes and maximum run speeds.

| Tube | | | Max Fill Vol ^a (mL) | Required Accessory | | Max Speed ^{b/} RCF/ k Factor |
|-----------------------|--|---------------------|--------------------------------|--------------------|--|--|
| Dimensions and Volume | Description | Part Number | | Description | Part Number | |
| 38 × 102 mm 100 mL | polypropylene Quick-Seal tube | 345776 | 100 | none | — | 18 000 rpm 47 900 × g 566 |
| 38 × 102 mm 100 mL | Ultra-Clear Quick-Seal tube | 345778 | 100 | none | — | 18 000 rpm 47 900 × g 566 |
| 38 × 102 mm 100 mL | polypropylene bottle w/cap assembly | 355624 ^c | 94 | none | — | 18 000 rpm 47 900 × g 566 |
| 38 × 102 mm 70 mL | polycarbonate bottle w/cap assembly | 355620 | 70 | none | — | 18 000 rpm 47 900 × g 566 |
| 29 × 104 mm 50 mL | polycarbonate open-top tube ^d | 363647 | 50 | adapter | 347539 ^e | 18 000 rpm 44 000 × g — |
| 29 × 104 mm 50 mL | polypropylene open-top tube ^d | 357007 | 50 | adapter | 347539 ^e | 18 000 rpm 44 000 × g — |
| 29 × 104 mm 50 mL | polycarbonate bottle w/screw cap | 357002 | 34 | adapter | 347539 ^e | 18 000 rpm 44 000 × g — |
| 29 × 104 mm 50 mL | polypropylene bottle w/screw cap | 357003 | 34 | adapter | 347539 ^e | 18 000 rpm 44 000 × g — |
| 11 × 38 mm 1.8 mL | polyethylene micro-centrifuge tube | 340196 | 1.8 | adapters | 344497 ^h inside 347539 ^e | 18 000 rpm 35 000 × g — |

^a Above 20°C fill polypropylene tubes at least half full.

^b Maximum speeds listed are guidelines only. These speeds have been achieved in reliability tests at Beckman Coulter, but, because of manufacturing variances, no guarantee of performance or fit is expressed or implied.

^c This part number is for the complete bottle assembly; to order separate components, part numbers are: bottle only, 355626; cap, 355625; cap O-ring, 889633.

^d A cap is available for these tubes, but it cannot be used in the JA-18 rotor. For a cap to use when storing samples, order cap 356262.

^e Polypropylene.

^f Commercially available. Observe manufacturer's speed and fill volume guidelines.

^g Do not use the rotor lid when using these tube/adapter combinations, as the lid will not seat properly. Do not use these tube/adapter combinations in this rotor in an Avanti J series centrifuge.

^h Delrin. Delrin is a registered trademark of E. I. Du Pont de Nemours & Company.

ⁱ Recommended speed at temperature of 20°C or less; at higher temperatures, reduce speed to 11 000 rpm.

^j Each adapter holds three tubes.

— Continued

Table 1. Available Tubes and Bottles for the JA-18 Fixed Angle Rotor (continued)

| Tube | | | Max Fill Vol ^a (mL) | Required Accessory | | Max Speed ^{b/} RCF/ k Factor |
|-----------------------|---|-------------|--------------------------------|--------------------|--|---|
| Dimensions and Volume | Description | Part Number | | Description | Part Number | |
| 11 × 39 mm 1.5 mL | polypropylene microcentrifuge tube (natural) | 357448 | 1.5 | adapters | 344497 ^h inside 347539 ^e | 18 000 rpm 35 000 × <i>g</i> — |
| 11 × 39 mm 1.5 mL | polypropylene microcentrifuge tube (natural) | 356090 | 1.5 | adapters | 344497 ^h inside 347539 ^e | 18 000 rpm 35 000 × <i>g</i> — |
| 11 × 39 mm 1.5 mL | polypropylene microcentrifuge tube (blue) | 356091 | 1.5 | adapters | 344497 ^h inside 347539 ^e | 18 000 rpm 35 000 × <i>g</i> — |
| 11 × 39 mm 1.5 mL | polypropylene microcentrifuge tube (green) | 356092 | 1.5 | adapters | 344497 ^h inside 347539 ^e | 18 000 rpm 35 000 × <i>g</i> — |
| 11 × 39 mm 1.5 mL | polypropylene microfuge tube (yellow) | 356093 | 1.5 | adapters | 344497 ^h inside 347539 ^e | 18 000 rpm 35 000 × <i>g</i> — |
| 11 × 39 mm 1.5 mL | polypropylene microcentrifuge tube (orange) | 356094 | 1.5 | adapters | 344497 ^h inside 347539 ^e | 18 000 rpm 35 000 × <i>g</i> — |
| 11 × 38 mm 1.5 mL | polypropylene microcentrifuge tube (natural) (separate cap) | 343169 | 1.5 | adapters | 344497 ^h inside 347539 ^e | 18 000 rpm 35 000 × <i>g</i> — |
| 30 × 115 mm 50 mL | conical tube | f | 37 | adapter | 356963 ^{gh} | 14 000 rpm 29 000 × <i>g</i> — |
| 17 × 120 mm 15 mL | conical tube | f | 15 | adapter | 356962 ^{gh} | 15 000 rpm ⁱ 33 300 × <i>g</i> — |
| 13 × 100 mm 10 mL | round-bottom tube | f | 10 | adapter | 356975 ^{hj} | 14 000 rpm ⁱ 29 000 × <i>g</i> — |
| 12 × 75 mm 3 mL | round-bottom tube | f | 3 | adapter | 356969 ^{hj} | 14 000 rpm ⁱ 29 000 × <i>g</i> — |

^a Above 20°C fill polypropylene tubes at least half full.

^b Maximum speeds listed are guidelines only. These speeds have been achieved in reliability tests at Beckman Coulter, but, because of manufacturing variances, no guarantee of performance or fit is expressed or implied.

^c This part number is for the complete bottle assembly; to order separate components, part numbers are: bottle only, 355626; cap, 355625; cap O-ring, 889633.

^d A cap is available for these tubes, but it cannot be used in the JA-18 rotor. For a cap to use when storing samples, order cap 356262.

^e Polypropylene.

^f Commercially available. Observe manufacturer's speed and fill volume guidelines.

^g Do not use the rotor lid when using these tube/adapter combinations, as the lid will not seat properly. Do not use these tube/adapter combinations in this rotor in an Avanti J series centrifuge.

^h Delrin. Delrin is a registered trademark of E. I. Du Pont de Nemours & Company.

ⁱ Recommended speed at temperature of 20°C or less; at higher temperatures, reduce speed to 11 000 rpm.

^j Each adapter holds three tubes.

- If you are using an Avanti J series centrifuge (except Avanti J-E), select the JA-18.
- If you are using an Avanti J-E or a microprocessor-controlled J2 or J6 series centrifuge, enter rotor code **18**. Refer to your centrifuge instruction manual for more information.

INSTALLING THE ROTOR

1. Lubricate J2 and J6 series centrifuge drive hubs with a thin, even coat of Spinkote (306812) to prevent the rotor from sticking. Avanti J series centrifuges have Delrin² rings on the drive hubs to prevent rotor sticking, and do not require lubrication.

Two metal pins inside the rotor drive hole engage with teeth on the centrifuge drive spindle hub to prevent the rotor from slipping during acceleration and deceleration (see Figure 2). When the rotor is properly installed, the pins sit either in the drive hub grooves or on top of the hub surface (see Figure 3).

The rotor pins are positioned parallel to the BECKMAN COULTER name engraved at the center of the rotor body. Knowing the pin orientation before you install the rotor will help to ensure that you position the rotor properly on the hub, minimizing the chance of hub damage.

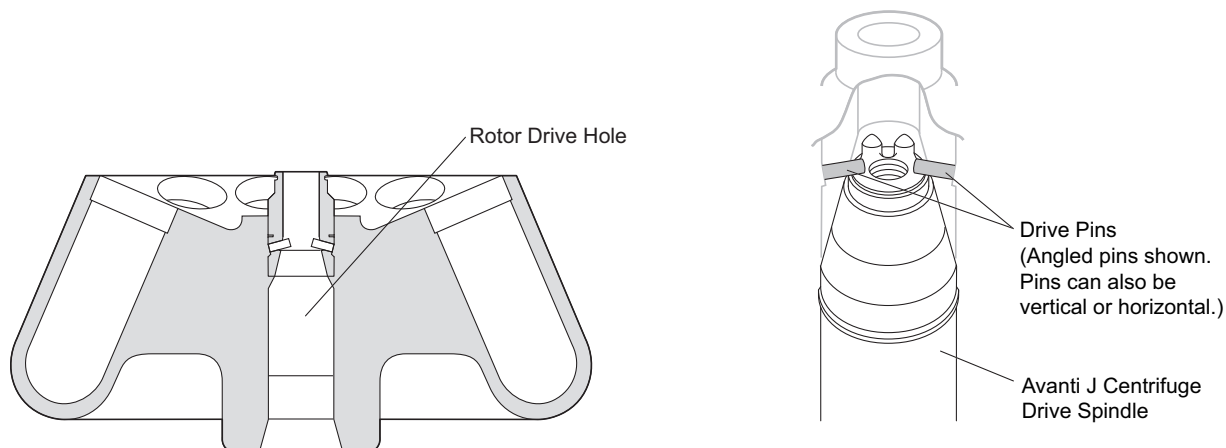

Figure 2. Rotor Drive Pin Location and Orientation

² Delrin is a registered trademark of E. I. Du Pont de Nemours & Company.

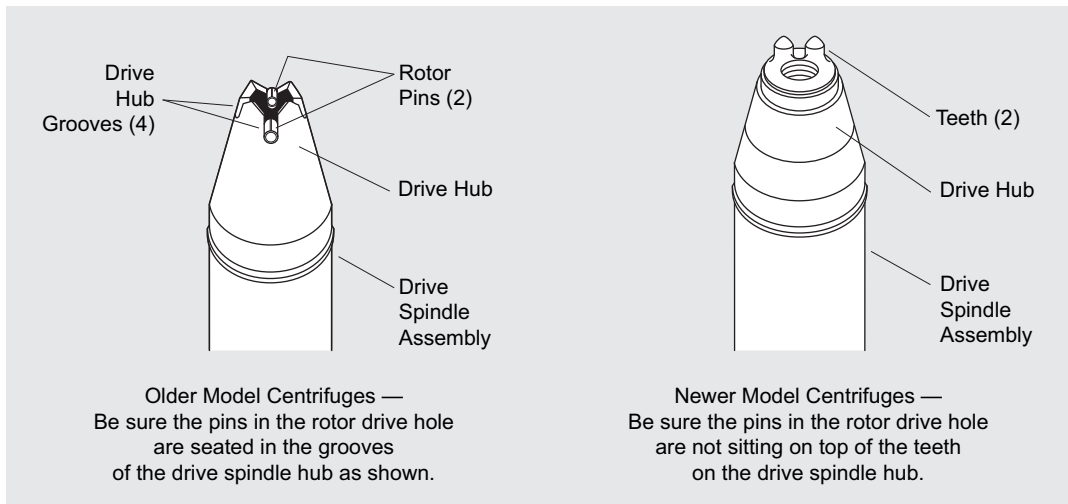
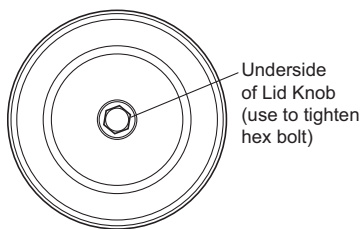

Figure 3. Centrifuge Drive Spindle Hub Configurations

2. Turn the rotor until the BECKMAN COULTER name is either horizontal or perpendicular to the drive hub pins or teeth. Alternately, rotate the drive spindle to align the hub pins or teeth with the rotor drive pins.
3. Carefully lower the rotor straight down onto the centrifuge drive spindle hub. Do not drop the rotor onto the hub.
4. Slowly turn the rotor, making sure that it is properly seated on the drive spindle hub. In rare cases, the rotor pins can rest on top of the hub pins or teeth and not seat on the hub surface. This can prevent the rotor from being secured to the drive spindle and may cause a rotor mishap during operation.
5. Place the lid on the rotor, fitting the underside of the lid knob over the hex bolt. The lid knob acts as a wrench for tightening and loosening the tie-down mechanism.
6. Turn the lid knob to the right (clockwise) to attach the rotor to the hub.



REMOVAL AND SAMPLE RECOVERY

**CAUTION**

If disassembly reveals evidence of leakage, you should assume that some fluid escaped the rotor. Apply appropriate decontamination procedures to the centrifuge and accessories.

1. Unscrew the rotor lid to release the rotor from the spindle hub.
2. Remove the rotor by lifting it straight up and off the drive spindle. If the rotor sticks to the drive spindle, a rotor removal tool (346965) may be used (see Figure 4).

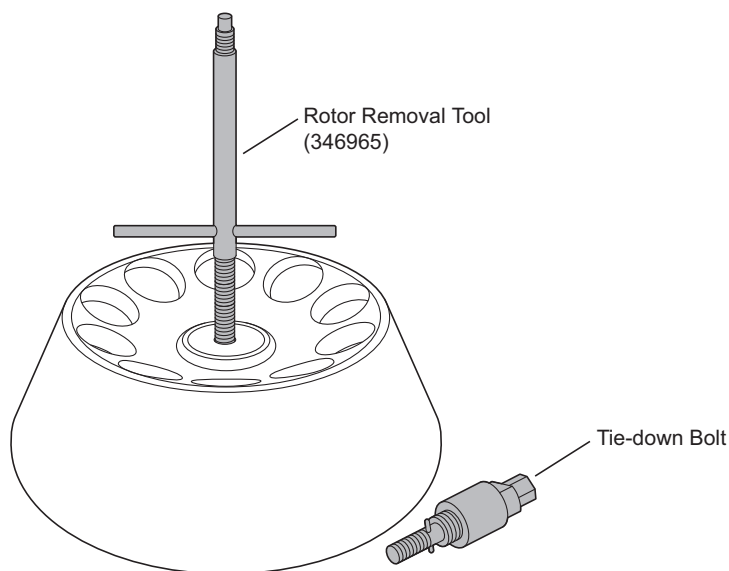
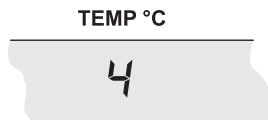

Figure 4. Using the Rotor Removal Tool

- a. Remove the lid and use an adjustable wrench to unscrew the tie-down bolt assembly from the rotor. Set the bolt assembly aside.
- b. Screw the larger end of the rotor removal tool into the threaded opening. As the removal tool tightens down, it pushes against the drive hub, forcing the rotor up and off of the hub.

- c. Unscrew the removal tool.
- d. Reassemble the tie-down bolt in the rotor and tighten it securely with the adjustable wrench.
- e. Remove the rotor from the centrifuge.

TEMPERATURE



To ensure that the JA-18 rotor reaches the required temperature during the run, follow the appropriate instructions below for the model of J centrifuge being used.

Avanti J Series Centrifuges

Enter the run temperature according to the instructions in your centrifuge instruction manual. No additional input is required.

Microprocessor-Controlled J2 and J6 Series Centrifuges (Models J2-MI, J2-MC, J6-MI, and J6-MC)

Enter rotor code **18**, then follow the steps below.

1. Press the [TEMP] key on the centrifuge control panel and then use the keypad to enter the sample temperature.
2. Find the compensation value in Table 3 or 4 that corresponds with the set temperature and run speed. The compensation values listed are approximates for all centrifuge models. If precise temperature control is required, determine the compensation settings empirically as follows:
 - a. Fill the rotor with water-filled tubes or bottles. Precool the rotor and water to the required temperature.
 - b. Place the filled, precooled rotor in the centrifuge and run the system for at least 1/2 hour.

- c. Measure the water temperature. If it is lower than the required run temperature, enter positive compensation units during run setup following steps 3 and 4 below. If it is higher than the required run temperature, enter negative compensation units during run setup, also using steps 3 and 4, below.
 - d. Discard the water. Fill tubes with sample, load tubes into the rotor, and precool the system to the required temperature before starting the run.
3. Press [COMP ADJ]. the word “COMP” flashes below the TEMPERATURE display and the display flashes.
 4. Use the keypad to enter the desired compensation value. Press the [±.] key to enter a minus sign; pressing it again will remove the minus sign.
 5. Check the temperature display. (If the entry is incorrect, press [CE] and reenter the digits.)
 6. When the entry is correct, press [ENTER/RECALL].

NOTE

To clear a COMP ADJ entry, press [COMP ADJ], [0], and [ENTER/RECALL].

Analog J2 Series Centrifuges

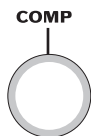
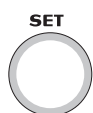

Enter the required run temperature and the appropriate temperature compensation units (see Table 2 or 5) on the centrifuge control panel as follows.

1. Turn the SET knob to the required sample temperature.
2. Find the compensation value that corresponds to the required temperature and run speed. The compensation values listed are approximate for all centrifuge models. If precise temperature control is required, follow the steps in **Microprocessor-Controlled J2 and J6 Series Centrifuges**, above.

Table 2. Temperature Compensation Settings for the Models J2-HS and J2-21 Centrifuges. Interpolate if intermediate values are required.

| Rotor Speed (rpm) | Required Sample Temperature (°C, green bar) | | | | | | |
|-------------------|---|------|-----|-----|-----|-----|-----|
| | -20° | -10° | 2° | 5° | 10° | 20° | 40° |
| 18 000 | N | N | N | N | N | -10 | -7 |
| 17 000 | N | N | N | -10 | -9 | -8 | -6 |
| 16 000 | N | N | -10 | -10 | -9 | -7 | -5 |
| 12 000 | N | -6 | -6 | -6 | -5 | -4 | -3 |
| 8 000 | -5 | -4 | -4 | -3 | -2 | -1 | 0 |
| 5 000 | -4 | -3 | -2 | -2 | -1 | 0 | 0 |

An “N” indicates that the rotor cannot achieve the required temperature at this speed.

Table 3. Temperature Compensation Settings for the Models J2-MI and J2-MC Centrifuges. Interpolate if intermediate values are required.

| Rotor Speed (rpm) | Required Sample Temperature (°C) | | | | | | |
|-------------------|----------------------------------|------|----|----|-----|-----|-----|
| | -20° | -10° | 2° | 5° | 10° | 20° | 40° |
| 18 000 | N | N | N | N | N | -9 | -7 |
| 17 000 | N | N | N | -9 | -9 | -8 | -6 |
| 16 000 | N | N | -9 | -9 | -9 | -8 | -5 |
| 12 000 | N | -9 | -8 | -6 | -4 | -4 | -3 |
| 8 000 | -5 | -4 | -3 | -3 | -2 | -1 | 0 |
| 5 000 | -4 | -3 | -2 | -2 | -1 | 0 | 0 |

An “N” indicates that the rotor cannot achieve the required temperature at this speed.

Table 4. Temperature Compensation Settings for the J6 Series Centrifuges. Interpolate if intermediate values are required.

| Rotor Speed (rpm) | Required Sample Temperature (°C) | | | |
|-------------------|----------------------------------|-----|-----|-----|
| | 2° | 10° | 20° | 40° |
| 6 000 | -3 | -2 | 0 | N |
| 4 000 | -2 | 0 | 0 | N |
| 2 000 | -1 | 0 | 0 | N |

An “N” indicates that the rotor cannot achieve the required temperature at this speed.

Table 5. Temperature Compensation Settings
for the Model J2-HC Centrifuge.
Interpolate if intermediate values are required.

| Rotor Speed (rpm) | Required Sample Temperature (°C) | | | | | | |
|-------------------|----------------------------------|------|-----|-----|-----|-----|-----|
| | -20° | -10° | 2° | 5° | 10° | 20° | 40° |
| 18 000 | N | N | N | N | N | -8 | -4 |
| 17 000 | N | N | N | -10 | -9 | -8 | -3 |
| 16 000 | N | N | -10 | -9 | -8 | -7 | -2 |
| 12 000 | N | -6 | -6 | -5 | -4 | -3 | -1 |
| 8 000 | -3 | -2 | -2 | -1 | -1 | 0 | N |
| 5 000 | -1 | -1 | -1 | -1 | 0 | +1 | N |

An "N" indicates that the rotor cannot achieve the required temperature at this speed.

RUN TIMES

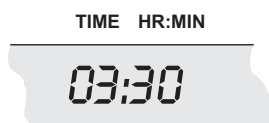

The k factor of the rotor is a measure of the rotor's pelleting efficiency. Beckman Coulter has calculated the k factors for all of its rotors, at maximum speed with full tubes, using the following formula:

$$k = \frac{\ln(r_{\max}/r_{\min})}{\omega^2} \times \frac{10^{13}}{3600} \quad (1)$$

where ω is the angular velocity of the rotor in radians per second ($\omega = 0.105 \times \text{rpm}$), r_{\max} is the maximum radius, and r_{\min} is the minimum radius.

After substitution:

$$k = \frac{(2.533 \times 10^{11}) \ln(r_{\max}/r_{\min})}{\text{rpm}^2} \quad (2)$$

In the JA-18 rotor, the k factor is 566 for full 100-mL tubes at maximum speed. For containers that nominally hold less than 100 mL, the k factors will be different. Calculate the k factors for these containers using equation (2).

Use the k factor in the following equation to estimate the run time t (in hours) required to pellet particles of known sedimentation coefficient s (in Svedberg units, S).

$$t = \frac{k}{s} \quad (3)$$

Run times can be estimated for centrifugation at less than maximum speed by adjusting the k factor as follows:

$$k_{\text{adj}} = k_{\text{rated}} \left(\frac{18\,000}{\text{actual run speed}} \right)^2 \quad (4)$$

Run times can also be estimated from data established in prior experiments using a different rotor if the k factor of the previous rotor is known. For any two rotors, a and b,

$$\frac{t_a}{t_b} = \frac{k_a}{k_b} \quad (5)$$

where the k factors have been adjusted for the actual run speed used.

For more information on k factors, see *Use of k Factor for Estimating Run Times from Previously Established Run Conditions* (publication DS-719).

RUN SPEEDS

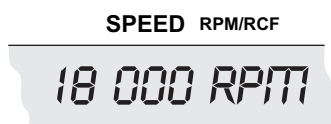

The centrifugal force at a given radius in a rotor is a function of speed. Comparisons of forces between different rotors are made by comparing the rotors' relative centrifugal fields (RCF). When rotational speed is adjusted so that identical samples are subjected to the same rcf in two different rotors, the samples are subjected to the same force. The RCF at a number of rotor speeds is provided in Table 6.

Do not select rotational speeds higher than the maximums you have determined to be appropriate for your protocols (in no case above 18 000 rpm or the limit shown in Table 1). In addition, when centrifuging solutions more dense than 1.2 g/mL in this rotor, calculate the reduced maximum allowable rotor speed:

$$\text{reduced maximum speed} = (18\,000 \text{ rpm}) \sqrt{\frac{1.2 \text{ g/mL}}{\text{density of tube contents}}} \quad (6)$$

Note, however, that the use of this formula may still produce maximum speed figures higher than the limitations imposed by the use of certain tubes or adapters (see Table 1). In such cases, use the lower of the two figures.

Table 6. Relative Centrifugal Fields for the JA-18 Rotor.

Entries in this table are calculated from the formula

$$RCF = 1.12 r (RPM/1000)^2$$

and then rounded to three significant digits.

| Rotor Speed (rpm) | Relative Centrifugal Field ($\times g$) | | |
|-------------------|---|---------------------|----------------------|
| | At r_{max} (132 mm) | At r_{av} (98 mm) | At r_{min} (64 mm) |
| 18 000 | 47 900 | 35 600 | 23 200 |
| 17 000 | 42 700 | 31 700 | 20 700 |
| 16 000 | 37 800 | 28 100 | 18 400 |
| 15 000 | 33 300 | 24 700 | 16 100 |
| 14 000 | 29 000 | 21 500 | 14 000 |
| 13 000 | 25 000 | 18 500 | 12 100 |
| 12 000 | 21 300 | 15 800 | 10 300 |
| 11 000 | 17 900 | 13 300 | 8 670 |
| 10 000 | 14 800 | 11 000 | 7 170 |
| 9 000 | 12 000 | 8 890 | 5 810 |
| 8 000 | 9 460 | 7 020 | 4 590 |
| 7 000 | 7 240 | 5 380 | 3 510 |
| 6 000 | 5 320 | 3 950 | 2 580 |
| 5 000 | 3 700 | 2 740 | 1 790 |
| 4 000 | 2 370 | 1 760 | 1 150 |
| 3 000 | 1 330 | 987 | 645 |
| 2 000 | 591 | 439 | 286 |
| 1 000 | 147 | 109 | 71 |

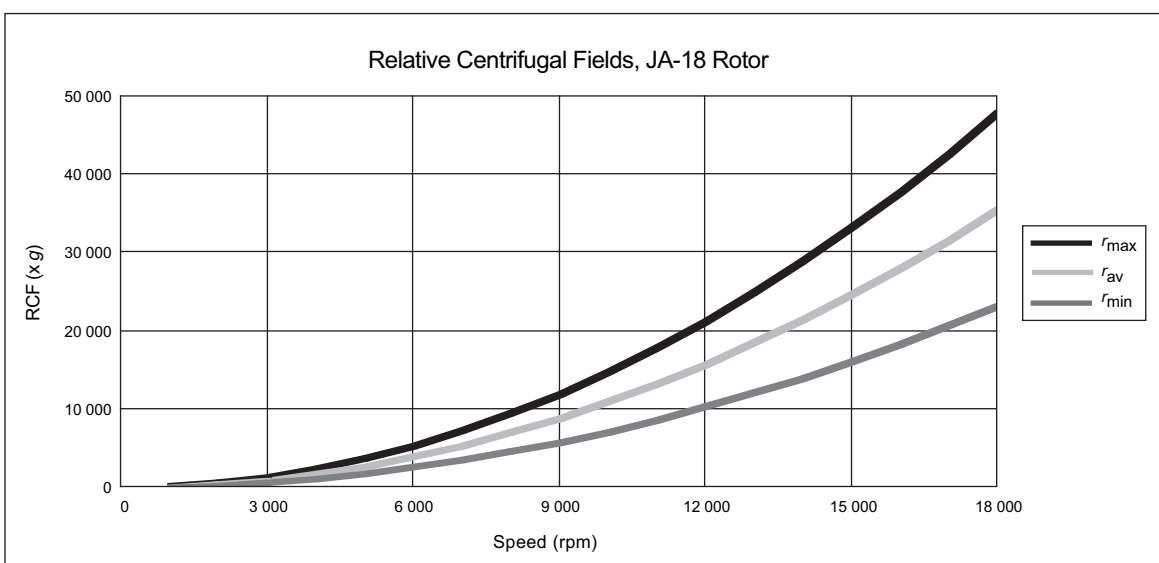

CARE AND MAINTENANCE

MAINTENANCE

NOTE

Do not use sharp tools on the rotor that could cause scratches in the rotor surface. Corrosion begins in scratches and may open fissures in the rotor with continued use.

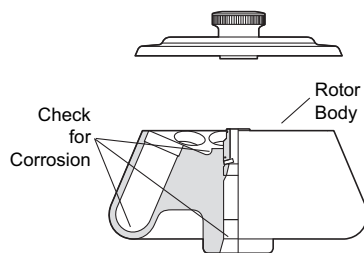

- Periodically (at least monthly) inspect the rotor, especially inside cavities, for rough spots or pitting, white powder deposits (frequently aluminum oxide), or heavy discoloration. If any of these signs are evident, do not run the rotor. Contact your Beckman Coulter representative for information about the Field Rotor Inspection Program and the rotor repair center.
- Before using the rotor, inspect the rotor drive pins to ensure that they are not damaged. Damaged drive pins can prevent the rotor from seating properly on the centrifuge drive hub (Avanti J series centrifuges only). To inspect the drive pins, turn the rotor upside down and look into the drive hole in the center of the rotor. If the drive pins appear damaged, contact Beckman Coulter Field Service.
- Regularly lubricate the metal threads in the rotor with a thin, even coat of Spinkote lubricant (306812). Failure to keep these threads lubricated can result in damaged threads.
- Regularly apply Spinkote lubricant (306812) to the centrifuge drive spindle to prevent the rotor from sticking (not required with Avanti J series centrifuges).

Refer to Appendix A in *Rotors and Tubes* for chemical compatibilities of rotor and accessory materials. Your Beckman Coulter representative provides contact with the Field Rotor Inspection Program and the rotor repair center.

CLEANING

Wash the rotor and rotor components immediately if salts or other corrosive materials are used or if spillage has occurred. Do not allow corrosive materials to dry on the rotor.

Under normal use, wash the rotor frequently (at least weekly) to prevent buildup of residues.

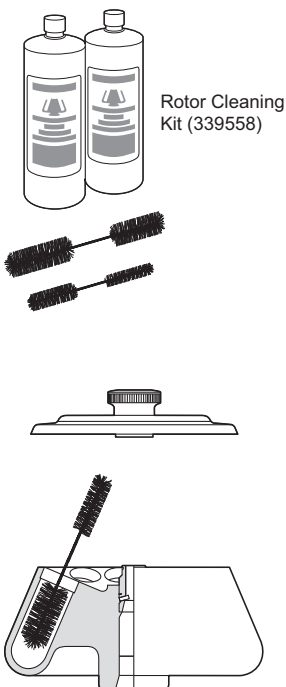

1. Wash the rotor and lid in a mild detergent, such as Beckman Solution 555 (339555), that won't damage the rotor. The Rotor Cleaning Kit (339558) contains two special plastic-coated brushes and two quarts of Solution 555 for use with rotors and accessories. Dilute the detergent 10 to 1 with water.

NOTE

Do not wash rotor components in a dishwasher. Do not soak in detergent solution for long periods, such as overnight.

2. Thoroughly rinse the cleaned rotor and components with distilled water.
3. Air-dry the rotor and lid upside down. *Do not use acetone to dry the rotor.*

Clear metal threads every 6 months or as necessary. Use a brush and concentrated Solution 555. Rinse and dry thoroughly, then lubricate lightly but evenly with Spinkote to coat all threads.

NOTE

The one-piece cap assembly for polypropylene bottle assembly 355624 contains an O-ring seal. If you remove the O-ring for cleaning or replacement, be careful not to damage the groove in the cap. The bottle cap and sealing surface of the O ring must be thoroughly dry before use.

DECONTAMINATION



If the rotor (and/or accessories) becomes contaminated with radioactive material, it should be decontaminated using a solution that will not damage the anodized surfaces. Beckman Coulter has tested a number of solutions and found two that do not harm anodized aluminum: RadCon Surface Spray or IsoClean Solution (for soaking),³ and Radiacwash.⁴

NOTE

IsoClean can cause fading of colored anodized surfaces. Use it only when necessary and remove it promptly from surfaces.

While Beckman Coulter has tested these methods and found that they do not damage components, no guarantee of decontamination is expressed or implied. Consult your laboratory safety officer regarding the proper decontamination methods to use.



If the rotor or other components are contaminated with toxic or pathogenic materials, follow appropriate decontamination procedures as outlined by your laboratory safety officer.

STERILIZATION AND DISINFECTION

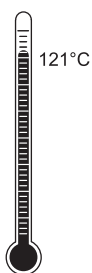

- The rotor and all rotor components can be autoclaved at 121°C for up to an hour. Remove the lid from the rotor and place the rotor and lid in the autoclave upside down.
- Ethanol (70%)⁵ may be used on all rotor components, including those made of plastic. Bleach (sodium hypochlorite) may be used, but may cause discoloration of anodized surfaces. Use the minimum immersion time for each solution, per laboratory standards.

³ In U.S., contact Nuclear Associates (New York); in Eastern Europe and Commonwealth States, contact Victoreen GmbH (Munich); in South Pacific, contact Gammasonics Pty. Ltd. (Australia); in Japan, contact Toyo Medic Co. Ltd. (Tokyo).

⁴ In U.S., contact Biodex Medical Systems (Shirley, New York); internationally, contact the U.S. office to find the dealer closest to you.

⁵ Flammability hazard. Do not use in or near operating centrifuges.

While Beckman Coulter has tested these methods and found that they do not damage the rotor or components, no guarantee of sterility or disinfection is expressed or implied. When sterilization or disinfection is a concern, consult your laboratory safety officer regarding proper methods to use.

Refer to publication IN-192, included in each box of tubes or bottles, for tube and bottle sterilization and disinfection procedures.

STORAGE

When the rotor is not in use, store it in a dry environment (not in the instrument) with the lid removed to allow air circulation so moisture will not collect in the tube cavities.

RETURNING A ROTOR

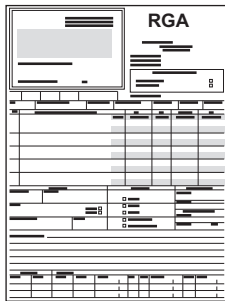

Before returning a rotor or accessory for any reason, prior permission (a Returned Goods Authorization form) must be obtained from Beckman Coulter, Inc. This RGA form may be obtained from your local Beckman Coulter sales office. It should contain the following information:

- serial number,
- history of use (approximate frequency of use),
- reason for the return,
- original purchase order number, billing number, and shipping number, if possible,
- name and phone number of the person to be notified upon receipt of the rotor or accessory at the factory, and
- name and phone number of the person to be notified about repair costs, etc.

To protect our personnel, it is the customer's responsibility to ensure that the parts are free from pathogens and/or radioactivity. Sterilization and decontamination must be done before returning the parts. Smaller items (such as tubes, bottles, etc.) should be enclosed in a sealed plastic bag.

*All parts must be accompanied by a note, plainly visible on the outside of the box or bag, stating that they are safe to handle and that they are not contaminated with pathogens or radioactivity. **Failure to attach this notification will result in return or disposal of the items without review of the reported problem.***

Use the address label printed on the RGA form when mailing the rotor and/or accessories.

Customers located outside the United States should contact their local Beckman Coulter office.

SUPPLY LIST

NOTE

Publications referenced in this manual can be obtained by calling Beckman Coulter at 1-800-742-2345 in the United States, or by contacting your local Beckman Coulter office.

Contact Beckman Coulter Sales (1-800-742-2345 in the United States) or your local Beckman Coulter office, or see the *Beckman Coulter High Performance, High Speed, High Capacity Rotors, Tubes, and Accessories* catalog (BR-8102, available at www.beckmancoulter.com) for detailed information on ordering parts and supplies. For your convenience, a partial list is given below.

REPLACEMENT ROTOR PARTS

| | |
|--|--------|
| JA-18 rotor assembly with magnets (rotors manufactured Jan. 2002 and later) | 369679 |
| JA-18 rotor assembly (rotors manufactured through Dec. 2001) . . . | 346944 |
| Rotor lid assembly | 364845 |
| Rotor tie-down kit | 364917 |

OTHER

| | |
|--|-------------|
| Tubes, bottles, and accessories | see Table 1 |
| Quick-Seal Cordless Tube Topper kit, 60 Hz | 358312 |
| Quick-Seal Cordless Tube Topper kit, 50 Hz (Europe) | 358313 |
| Quick-Seal Cordless Tube Topper kit, 50 Hz (Great Britain) | 358314 |
| Quick-Seal Cordless Tube Topper kit, 50 Hz (Australia) | 358315 |
| Quick-Seal Cordless Tube Topper kit, 50 Hz (Canada) | 367803 |
| Tube Topper rack, 12 place | 348125 |
| Spinkote lubricant (2 oz) | 306812 |
| Silicone vacuum grease (1 oz) | 335148 |
| Rotor Cleaning Kit | 339558 |
| Beckman Solution 555 (1 qt) | 339555 |
| Rotor cleaning brush | 339379 |
| Rotor removal tool and lifting handle | 346965 |

J SERIES ROTOR WARRANTY

Subject to the conditions specified below and the warranty clause of the Beckman Coulter, Inc., terms and conditions of sale in effect at the time of sale, Beckman Coulter, Inc. agrees to correct either by repair, or, at its election, by replacement, any defects of material or workmanship which develop within seven (7) years after delivery of a J series rotor to the original buyer by Beckman Coulter, Inc. or by an authorized representative, provided that investigation and factory inspection by Beckman Coulter, Inc. discloses that such defect developed under normal and proper use. Should a Beckman Coulter centrifuge be damaged due to a failure of a rotor covered by this warranty, Beckman Coulter will supply free of charge all centrifuge parts required for repair.

REPLACEMENT

Any product claimed to be defective must, if requested by Beckman Coulter, Inc., be returned to the factory, transportation charges prepaid, and will be returned to Buyer with the transportation charges collect unless the product is found to be defective, in which case Beckman Coulter, Inc. will pay all transportation charges.

A defective rotor will be replaced by Beckman Coulter, Inc. at its then current list price less a credit based upon the age of the rotor (years since date of purchase). The Buyer shall not receive credit until the claimed defective rotor is returned to Beckman Coulter's Indianapolis, Indiana facility or delivered to a Beckman Field Service representative.

The replacement price (cost to Buyer) for the respective rotor shall be calculated as follows:

$$\text{Replacement price} = \text{Current rotor list price} \times \frac{\text{years}}{7}$$

CONDITIONS

1. Except as otherwise specifically provided herein, this warranty covers the rotor only and Beckman Coulter, Inc. shall not be liable for damage to accessories or ancillary supplies including but not limited to (i) tubes, (ii) tube caps, (iii) tube adapters, or (iv) tube contents.
2. This warranty is void if the rotor has been subjected to customer misuse such as operation or maintenance contrary to the instructions in the Beckman Coulter rotor or centrifuge manual.
3. This warranty is void if the rotor is operated with a rotor drive unit or in a centrifuge unmatched to the rotor characteristics, or is operated in a Beckman Coulter centrifuge that has been improperly disassembled, repaired, or modified.

DISCLAIMER

IT IS EXPRESSLY AGREED THAT THE ABOVE WARRANTY SHALL BE IN LIEU OF ALL WARRANTIES OF FITNESS AND OF THE WARRANTY OF MERCHANTABILITY AND THAT BECKMAN COULTER, INC. SHALL HAVE NO LIABILITY FOR SPECIAL OR CONSEQUENTIAL DAMAGES OF ANY KIND WHATSOEVER ARISING OUT OF THE MANUFACTURE, USE, SALE, HANDLING, REPAIR, MAINTENANCE, OR REPLACEMENT OF THE PRODUCT.



Beckman Coulter, Inc. • 250 S. Kraemer Blvd. • Brea, California 92821 U.S.A.
Sales and Service: 1-800-742-2345 • Internet: www.beckmancoulter.com • Printed in U.S.A.

© 2014 Beckman Coulter, Inc.
All rights reserved