

JA-20 Fixed Angle Rotor



**Used In Beckman Coulter J2, J6,
and Avanti J Series
Centrifuges**

Trademarks

Beckman Coulter, the stylized logo, Avanti, and Microfuge are trademarks of Beckman Coulter, Inc. and are registered in the USPTO.

All other trademarks, service marks, products, or services are trademarks of their respective holders.



SAFETY NOTICE

This safety notice summarizes information basic to the safe use of the rotor described in this manual. The international symbol displayed above is a reminder to the user that all safety instructions should be read and understood before operation or maintenance of this equipment is attempted. When you see the symbol on other pages throughout this publication, pay special attention to the specific safety information presented. Observance of safety precautions will also help to avoid actions that could damage or adversely affect the performance of the rotor. This rotor was developed, manufactured, and tested for safety and reliability as part of a Beckman Coulter centrifuge/rotor system. Its safety or reliability cannot be assured if used in a centrifuge not of Beckman Coulter's manufacture or in a Beckman Coulter centrifuge that has been modified without Beckman Coulter's approval.



Handle body fluids with care because they can transmit disease. No known test offers complete assurance that such fluids are free of micro-organisms. Some of the most virulent—Hepatitis (B and C) viruses, HIV (I–V), atypical mycobacteria, and certain systemic fungi—further emphasize the need for aerosol protection. Handle other infectious samples according to good laboratory procedures and methods to prevent spread of disease. Because spills may generate aerosols, observe proper safety precautions for aerosol containment. Do not run toxic, pathogenic, or radioactive materials in this rotor without taking appropriate safety precautions. Biosafe containment should be used when Risk Group II materials (as identified in the *World Health Organization Laboratory Biosafety Manual*) are handled; materials of a higher group require more than one level of protection.



The rotor and accessories are not designed for use with materials capable of developing flammable or explosive vapors. Do not centrifuge such materials in nor handle or store them near the centrifuge.



Although rotor components and accessories made by other manufacturers may fit in the JA-20 rotor, their safety in this rotor cannot be ascertained by Beckman Coulter. Use of other manufacturers' components or accessories in the JA-20 rotor may void the rotor warranty and should be prohibited by your laboratory safety officer. Only the components and accessories listed in this publication should be used in this rotor.



Make sure that filled containers are loaded symmetrically into the rotor and that opposing tubes are filled to the same level with liquid of the same density.



If disassembly reveals evidence of leakage, and pathogenic or radioactive materials are involved, you should assume that some fluid escaped the rotor. Apply appropriate decontamination procedures to the centrifuge and accessories.



Never exceed the maximum rated speed of the rotor and labware in use. Refer to the section on RUN SPEEDS.



Do not use sharp tools on the rotor that could cause scratches in the rotor surface. Corrosion begins in scratches and may open fissures in the rotor with continued use.

JA-20 FIXED ANGLE ROTOR

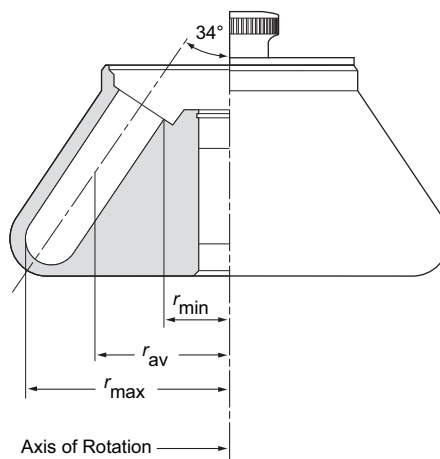

SPECIFICATIONS

Maximum speed	20 000 rpm
Critical speed range*	600 to 800 rpm
Density rating at maximum speed	1.2 g/mL
Maximum allowable imbalance of opposing loads	2 grams
Relative Centrifugal Field† at maximum speed	
At r_{\max} (108 mm)	48 400 × g
At r_{av} (70 mm)	31 400 × g
At r_{\min} (32 mm)	14 300 × g
k factor at maximum speed	769
Conditions requiring speed reductions	see RUN SPEEDS
Number of tube cavities	8
Available tubes	see Table 3
Nominal tube dimensions (largest tube)	29 × 104 mm
Nominal tube capacity (largest tube)	50 mL
Nominal rotor capacity	400 mL
Approximate acceleration time to maximum speed (rotor fully loaded)	1 1/2 min
Approximate deceleration time from maximum speed (rotor fully loaded)	2 1/2 min
Weight of fully loaded rotor	7.4 kg (16.5 lb)
Rotor material	aluminum
Rotor entry code for J2 and J6 series microprocessor- controlled centrifuges	20.2
Rotor entry code for Avanti J-E centrifuges	20

* Relative Centrifugal Field (RCF) is the ratio of the centrifugal acceleration at a specified radius and speed ($r\omega^2$) to the standard acceleration of gravity (g) according to the following formula:

$$\text{RCF} = \frac{r\omega^2}{g}$$

where r is the radius in millimeters, ω is the angular velocity in radians per second ($2\pi\text{RPM}/60$), and g is the standard acceleration of gravity (9807 mm/s^2). After substitution:

$$\text{RCF} = 1.12 r \left(\frac{\text{RPM}}{1000} \right)^2$$

DESCRIPTION

This rotor has been manufactured in a registered ISO 9001 or 13485 facility for use with the specified Beckman Coulter centrifuges.

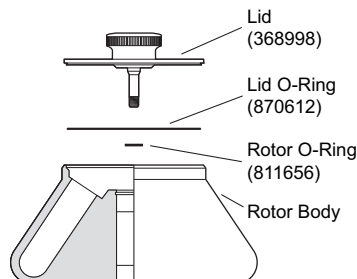

The JA-20, rated for 20 000 rpm, is a fixed angle rotor designed to centrifuge up to eight 50-mL tubes at a 34-degree angle to the axis of rotation. Used in Beckman Coulter J2, J6, and Avanti J series centrifuges, the rotor develops centrifugal forces that can efficiently pellet bacteria, cell membranes, and subcellular particles. Short-column methods (such as partially filled tubes) may also be used to isolate and band different classes of subcellular organelles. Up to 400 mL of gradient and sample can be centrifuged per run.

The rotor body and lid are made of aluminum and are anodized for corrosion resistance—the rotor is black and the lid is blue. O-rings made of Buna N rubber in the lid and rotor body maintain atmospheric pressure inside the rotor during centrifugation, if they are properly lubricated. Two vertical pins in the rotor drive hole mate with grooves in the centrifuge drive hub (in older model centrifuges), or with drive hub teeth (new model centrifuges), to prevent the rotor from slipping during acceleration and deceleration.

The rotor has been tested¹ to demonstrate containment of microbiological aerosols under normal conditions of the associated Beckman Coulter centrifuge when used and maintained as instructed.

The JA-20 rotor is warranted for 7 years (see the Warranty).

PREPARATION AND USE

Specific information about the JA-20 rotor is given here. Use the J Series Rotors and Tubes manual (JR-IM) along with this rotor manual for complete rotor and accessory operation.

¹ Validation of microbiological containment was done at an independent third-party testing facility (CAMR, Porton Down, UK, or USAMRIID, Ft. Detrick, MD, U.S.A.). Improper use or maintenance may affect seal integrity and thus containment.

NOTE

Although rotor components and accessories made by other manufacturers may fit in the JA-20 rotor, their safety in this rotor cannot be ascertained by Beckman Coulter. Use of other manufacturers' components or accessories in this rotor may void the rotor warranty and should be prohibited by your laboratory safety officer. Only the components and accessories listed in this publication should be used in this rotor.

PRERUN SAFETY CHECKS

Read the Safety Notice page at the front of this manual before using the rotor.

1. Make sure that the rotor and lid are clean and show no signs of corrosion or cracking.
2. Check the chemical compatibilities of all materials used. Refer to Chemical Resistances in Appendix A of the *J Rotors and Tubes Manual*.
3. Verify that the tubes and bottles being used are listed in Table 3.

ROTOR PREPARATION

For runs at other than room temperature, refrigerate or warm the rotor beforehand for fast temperature equilibration.

1. Be sure that metal threads in the rotor are clean and lightly but evenly lubricated with Spinkote lubricant (306812). Also ensure that O-rings are lightly but evenly coated with silicone vacuum grease (335148).
2. Load the filled containers symmetrically into the rotor. (Refer to TUBES AND BOTTLES on page 13 for information about containers.) If fewer than eight tubes are being run, they must be arranged symmetrically in the rotor (see Figure 1). Opposing tubes must be filled to the same level with liquid of the same density.

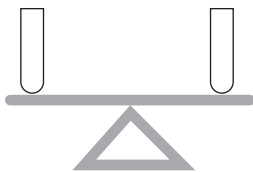

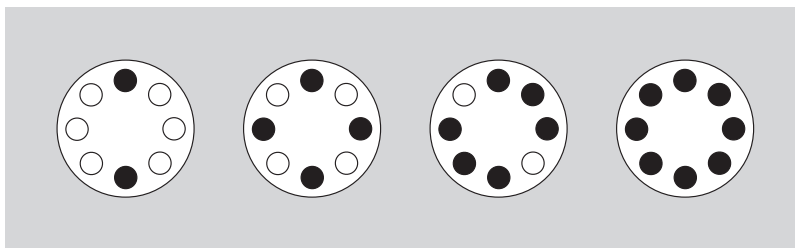

Figure 1. Arranging Tubes in the Rotor. Two, four, six, or eight tubes can be centrifuged per run if they are arranged in the rotor as shown.

OPERATION

- For low-temperature runs, precool the rotor in the centrifuge or in a refrigerator before use—especially before short runs—to ensure that the rotor reaches the set temperature. A suggested precooling cycle is a minimum of 30 minutes at 2000 rpm at the required temperature.
- If fluid containment is required, *use capped tubes or bottles*. It is strongly recommended that all containers carrying physiological fluids be capped to prevent leakage.
- If you are using an Avanti J series centrifuge, select the JA-20 rotor. If you are using an Avanti J-E centrifuge, enter rotor code **20**. If you are using a microprocessor-controlled J2 or J6 series centrifuge, enter rotor code **20.2**. Refer to your centrifuge instruction manual for additional information.

INSTALLING THE ROTOR

Two metal pins inside the rotor drive hole engage with teeth on the centrifuge drive hub to prevent the rotor from slipping during acceleration and deceleration (see Figure 2). When the rotor is properly installed, the pins sit either in the drive hub grooves or on top of the hub surface (see Figure 3).

In rotors manufactured since early 1997, the rotor pins are positioned parallel to the BECKMAN name engraved at the center of the rotor body (see Figure 4). Knowing the pin orientation before you install the rotor will help to ensure that you position the rotor properly on the hub, minimizing the chance of hub damage. Follow the steps below.

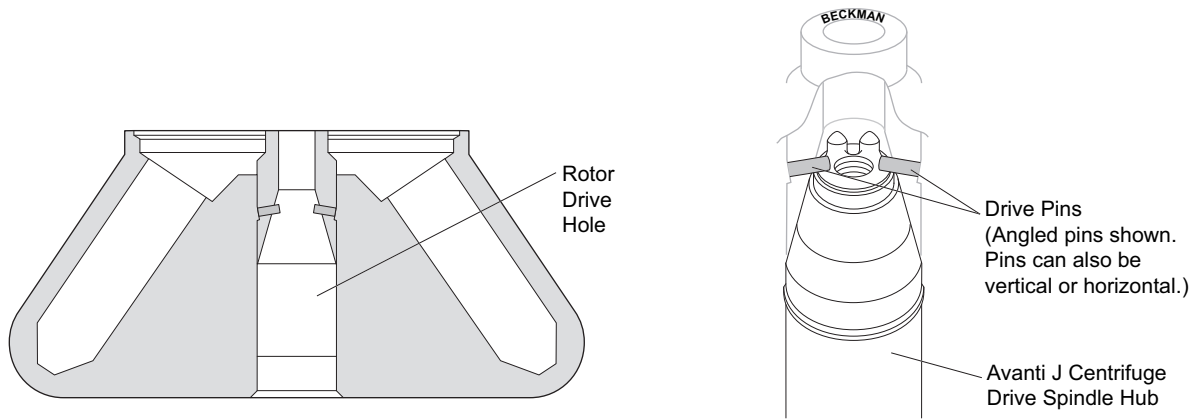

Figure 2. Rotor Drive Pin Location and Orientation

1. Turn the rotor until the BECKMAN name is either horizontal or perpendicular to the drive hub pins or teeth (see Figure 4). Alternately, rotate the drive shaft to align the drive shaft hub pins or teeth with the rotor drive pins.
2. Carefully lower the rotor straight down onto the centrifuge drive spindle hub.

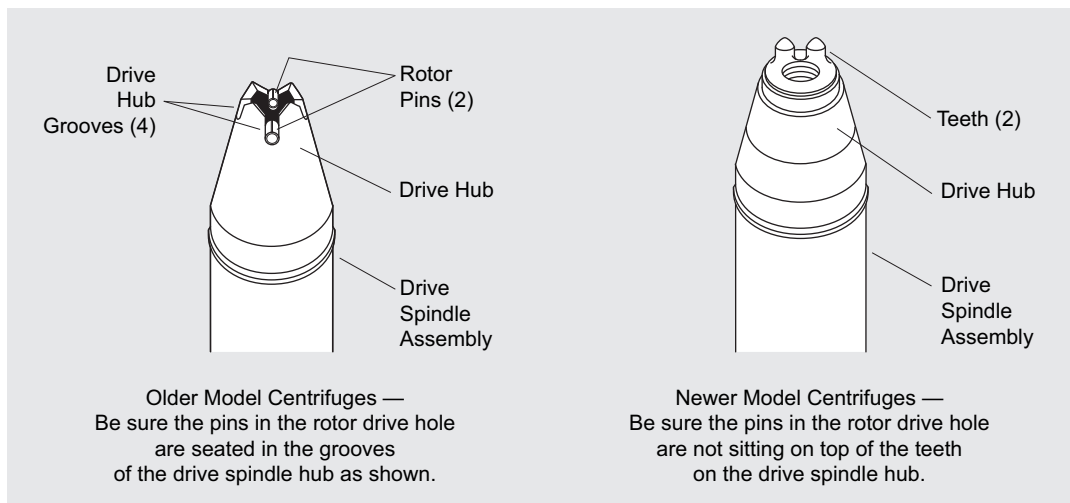

Figure 3. Centrifuge Drive Hub Configurations

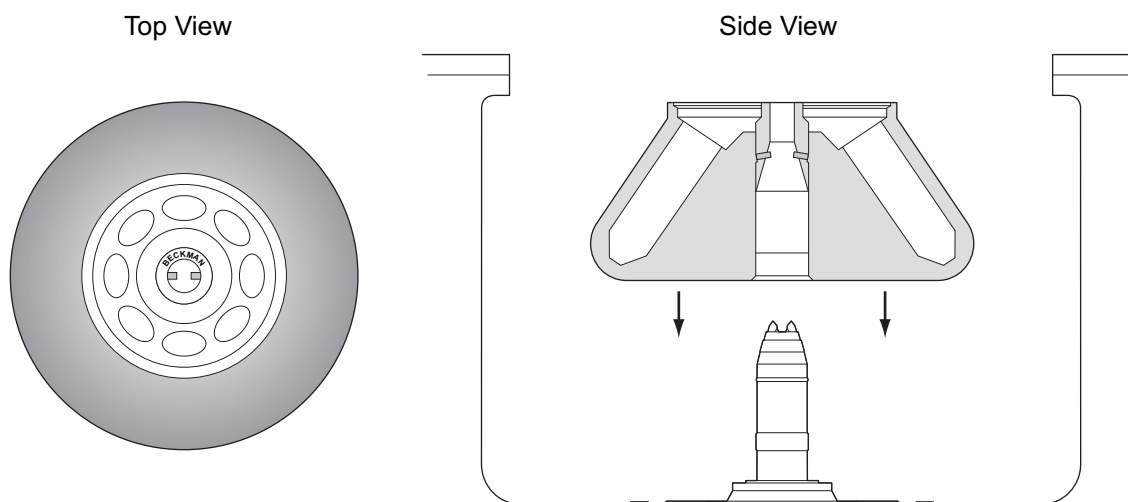

Figure 4. Installing the Rotor

3. Slowly turn the rotor, making sure that it is properly seated on the drive spindle hub. (In rare cases, the rotor pins can rest on top of the drive spindle hub pins or teeth and not seat on the hub surface. This can prevent the rotor from being secured to the drive spindle. Turning the rotor slightly after installing it will move the pins into proper position.)
4. Place the lid on the rotor and turn the lid knob to the right (clockwise) until secure. Do not overtighten.

TEMPERATURE



To ensure that the JA-20 rotor reaches the required temperature during the run, follow the appropriate instructions below for the model of J centrifuge being used.

Avanti J Series Centrifuges

Enter the run temperature according to the instructions in your centrifuge instruction manual. No additional input is required.

**Microprocessor-Controlled J2 and J6 Series Centrifuges
(Models J2-MI, J6-MI, J2-21M, J2-MC, J6-MC, and J2-21 M/E)**

Enter rotor code **20.2**, then follow the steps below.

1. Press the [TEMP] key on the centrifuge control panel and then use the keypad to enter the sample temperature.
2. Find the compensation value in Table 1 that corresponds with the set temperature and run speed. The compensation values listed in Table 1 are approximates for microprocessor-controlled centrifuges. If precise temperature control is required, determine the compensation settings empirically as follows:
 - a. Fill the rotor with water-filled tubes or bottles. Precool the rotor and water to the required temperature.
 - b. Place the filled, precooled rotor in the centrifuge and run the system for at least 1/2 hour.
 - c. Measure the water temperature. If it is lower than the required run temperature, enter positive compensation units during run setup following steps 3 and 4, below. If it is higher than the required run temperature, enter negative compensation units during run setup, also using steps 3 and 4, below.
 - d. Discard the water. Fill tubes with sample, load tubes into the rotor, and precool the system to the required temperature before starting the run.
3. Press [COMP ADJ]. The word “COMP” flashes below the TEMPERATURE display and the display flashes.
4. Use the keypad to enter the required compensation value. Press the [±.] key to enter a minus sign; pressing it again will remove the minus sign.
5. Check the temperature display. (If the entry is incorrect, press [CE] and reenter the digits.)
6. When the entry is correct, press [ENTER/RECALL].

NOTE

To clear a COMP ADJ entry, press [COMP ADJ], [0], and [ENTER/RECALL].

Analog J2 Series Centrifuges

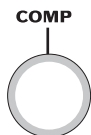
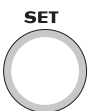

Enter the required run temperature and the appropriate temperature compensation units (see Table 1 or 2) on the centrifuge control panel as follows.

1. Turn the SET knob to the required sample temperature.
2. Find the compensation value (Table 1 for Models J2-HS and J2-21; Table 2 for Model J2-HC) that corresponds to the required temperature and run speed. Set the COMP dial to that setting. (Interpolate if intermediate values are required.)

Table 1. J2-21 and J2-HS Centrifuge Temperature Settings

Rotor Speed (rpm)	Required Sample Temperature (°C)						
	-20°	-10°	2°	5°	10°	20°	40°
20 000	N	N	-9	-8	-7	-7	-6
18 000	N	N	-6	-6	-5	-4	-3
15 000	-5	-4	-4	-4	-3	-2	-1
10 000	-2	-2	-1	0	0	0	0

An “N” indicates that the rotor cannot achieve the required temperature at this speed.

Table 2. J2-HC Centrifuge Temperature Settings

Rotor Speed (rpm)	Required Sample Temperature (°C)						
	-20°	-10°	2°	5°	10°	20°	40°
18 000	N	N	-6	-6	-5	-4	-3
15 000	-6	-5	-4	-4	-3	-3	-2
10 000	-4	-4	-3	-2	-2	-2	-2

An “N” indicates that the rotor cannot achieve the required temperature at this speed.

REMOVAL AND SAMPLE RECOVERY

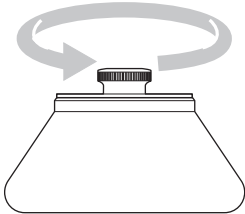

CAUTION

If disassembly reveals evidence of leakage, you should assume that some fluid escaped the rotor. Apply appropriate decontamination procedures to the centrifuge and accessories.

1. Unscrew the rotor lid to release the rotor from the spindle hub.
2. Remove the rotor by lifting it straight up and off the drive spindle. If the rotor sticks to the drive spindle hub, a collar adapter (338689) and rotor removal tool (338896) may be used.
 - a. Remove the lid and small O-ring from the rotor.
 - b. Slide the flanges of the collar into the empty O-ring groove.
 - c. Screw the larger end of the rotor removal tool into the threaded opening of the collar adapter. As the removal tool tightens down, it will push against the drive spindle hub, causing the rotor to rise.
 - d. Remove the tool and collar adapter from the rotor by reversing the above procedure.
 - e. Replace the O-ring in the groove.
 - f. Remove the rotor from the centrifuge.

NOTE

Lubricate J2 and J6 series centrifuge drive hubs with Spinkote to prevent the rotor from sticking. Avanti J series centrifuges have Delrin² rings on the hubs to prevent sticking and do not require lubrication.

² Delrin is a registered trademark of E. I. Du Pont de Nemours & Company.

TUBES AND BOTTLES

The JA-20 rotor uses the tubes and bottles listed in Table 3. Be sure to use only those items listed, and to observe the maximum speed limits and fill volumes shown. (Maximum fill volume is the maximum amount that can be centrifuged in the container listed.) Refer to Appendix A in *Rotors and Tubes* for chemical compatibilities of tube, bottle, and accessory materials.

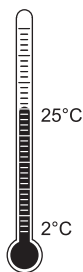

Temperature Limits

- Plastic containers have been centrifuge tested for use at temperatures between 2 and 25°C. For centrifugation at other temperatures, pretest tubes under anticipated run conditions.
- If plastic containers are frozen before use, make sure that they are thawed to at least 2°C prior to centrifugation.

Thickwall Tubes



Thickwall polypropylene and polycarbonate tubes can be run partially filled (at least half filled) with or without caps, but all opposing tubes for a run must be filled to the same level with liquid of the same density. Do not overfill capless tubes; be sure to note the fill volumes and run speeds shown in Table 3.



Polycarbonate and Polypropylene Bottles

Capped polycarbonate and polypropylene bottles may be centrifuged completely filled, or partially filled (not less than half full). Again, all opposing containers for a run must be filled to the same level. Be sure to note the reductions in run speed shown in Table 3 if bottles are partially filled.



Microfuge Tubes

Microfuge tubes are placed in multi-tube adapters for use in this rotor. The number and arrangement of tubes in opposing adapters should be balanced.

Table 3. Available Tubes and Bottles for the JA-20 Fixed Angle Rotor.
Use only the items listed here and observe fill volumes and maximum run speeds.

Tube			Max Fill Vol (mL)	Required Accessory		No. Tubes per Adapter	Max Speed ^a / RCF/ k Factor
Dimensions and Volume	Description	Part Number		Description	Part Number		
29 × 104 mm 50 mL	polycarbonate bottle assy, liquid-tight cap assy	357000 ^b	45	none	—	—	20 000 rpm 48 400 × g 769
29 × 104 mm 50 mL	polypropylene bottle assy, liquid-tight cap assy	357001 ^b	45	none	—	—	20 000 rpm 48 400 × g 769
29 × 104 mm 50 mL	polycarbonate bottle, screw-cap	357002	40	none	—	—	20 000 rpm 48 400 × g 769
29 × 104 mm 50 mL	polypropylene bottle, screw-cap	357003	40	none	—	—	20 000 rpm 48 400 × g 769
29 × 104 mm 50 mL	polycarbonate thickwall tube, snap-on cap	363647	36.5	white 29-mm cap red 29-mm cap green 29-mm cap yellow 29-mm cap blue 29-mm cap	356264 ^c 357359 ^c 357360 ^c 357361 ^c 357362 ^c	—	20 000 rpm 48 400 × g 769
29 × 104 mm 50 mL	polypropylene thickwall tube, snap-on cap	357005	36.5 ^d	white 29-mm cap red 29-mm cap green 29-mm cap blue 29-mm cap	356264 ^c 357359 ^c 357360 ^c 357361 ^c 357362 ^c	—	20 000 rpm 48 400 × g 769
29 × 104 mm 50 mL	polypropylene thickwall tube, no cap	357007	35 ^d	none	—	—	20 000 rpm 48 400 × g 769
29 × 105 mm 30 mL	glass tube ^e	e	e	adapter	870331 (rubber)	1	e
17 × 100 mm 15 mL	glass tube ^e	e	e	adapter	870329 (rubber)	1	e
16 × 100 mm 15 mL	glass tube ^e	e	e	adapter	870329 (rubber)	1	e

—continued

^a Maximum speeds listed are guidelines only. These speeds have been achieved in reliability tests at Beckman Coulter, but, because of manufacturing variances, no guarantee of performance or fit is expressed or implied.

^b Bottles 357000 and 357001 use cap 356284, cap assembly insert 358627 (order only as a replacement part), and O-ring 961582.

^c Polyethylene, package of 25.

^d Above 20°C fill polypropylene tubes at least half full.

^e Commercially available. Observe manufacturer's speed and fill volume guidelines.

Table 3. Available Tubes and Bottles for the JA-20 Fixed Angle Rotor (continued)

Tube			Max Fill Vol (mL)	Required Accessory		No. Tubes per Adapter	Max Speed ^a / RCF/ k Factor
Dimensions and Volume	Description	Part Number		Description	Part Number		
16 × 80 mm 10 mL	polycarbonate bottle, screw-cap	355672	10	adapter	342327 (polyethylene)/ 870329 (rubber)	1	20 000 rpm 43 500 × g 650
11 × 39 mm 1.8 mL	Microfuge tube, natural polyethylene	340196	1.8	adapter	344497 ^f	3	20 000 rpm 48 400 × g 769
11 × 39 mm 1.5 mL	Microfuge tube, natural polypropylene, snap-on cap	357448	1.5	adapter	344497 ^f	3	20 000 rpm 48 400 × g 769
11 × 39 mm 1.5 mL	Microfuge tube, natural polypropylene, snap-on cap	356090	1.5	adapter	344497 ^f	3	20 000 rpm 48 400 × g 769
11 × 39 mm 1.5 mL	Microfuge tube, blue polypropylene, snap-on cap	356091	1.5	adapter	344497 ^f	3	20 000 rpm 48 400 × g 769
11 × 39 mm 1.5 mL	Microfuge tube, green polypropylene, snap-on cap	356092	1.5	adapter	344497 ^f	3	20 000 rpm 48 400 × g 769
11 × 39 mm 1.5 mL	Microfuge tube, yellow polypropylene, snap-on cap	356093	1.5	adapter	344497 ^f	3	20 000 rpm 48 400 × g 769
11 × 39 mm 1.5 mL	Microfuge tube, orange polypropylene, snap-on cap	356094	1.5	adapter	344497 ^f	3	20 000 rpm 48 400 × g 769

^a Maximum speeds listed are guidelines only. These speeds have been achieved in reliability tests at Beckman Coulter, but, because of manufacturing variances, no guarantee of performance or fit is expressed or implied.

^b Bottles 357000 and 357001 use cap 356284, cap assembly insert 358627 (order only as a replacement part), and O-ring 961582.

^c Polypropylene, package of 25.

^d Above 20°C fill polypropylene tubes at least half full.

^e Commercially available. Observe manufacturer's speed and fill volume guidelines.

^f Delrin. Can be stacked; force will vary depending on tube position. Delrin is a registered trademark of E.I. Du Pont de Nemours & Company.

RUN TIMES

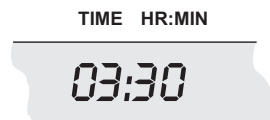

The k factor of the rotor is a measure of the rotor's pelleting efficiency. Beckman Coulter has calculated the k factors for all of its rotors, at maximum speed with full tubes, using the following formula:

$$k = \frac{\ln(r_{\max}/r_{\min})}{\omega^2} \times \frac{10^{13}}{3600} \quad (1)$$

where ω is the angular velocity of the rotor in radians per second ($\omega = 0.105 \times \text{rpm}$), r_{\max} is the maximum radius, and r_{\min} is the minimum radius.

After substitution:

$$k = \frac{(2.533 \times 10^{11}) \ln(r_{\max}/r_{\min})}{\text{rpm}^2} \quad (2)$$

In the JA-20 rotor, the k factor is 769 for full 50-mL tubes. For containers that nominally hold less than 50 mL, the k factors will be different. Calculate k factors for these containers using equation (2).

Use the k factor in the following equation to estimate the run time t (in hours) required to pellet particles of known sedimentation coefficient s (in Svedberg units, S).

$$t = \frac{k}{s} \quad (3)$$

For example, at 20 000 rpm, mammalian viruses ($s = 700 S$) can be pelleted in

$$t = \frac{769}{700} \approx 1.1 \text{ hours} \quad (4)$$

Run times can be estimated for centrifugation at less than maximum speed by adjusting the k factor as follows:

$$k_{\text{adj}} = k \left(\frac{20\,000}{\text{actual run speed}} \right)^2 \quad (5)$$

Run times can also be estimated from data established in prior experiments using a different rotor if the k factor of the previous rotor is known. For any two rotors, a and b,

$$\frac{t_a}{t_b} = \frac{k_a}{k_b} \quad (6)$$

For more information on k factors, see *Use of k Factor for Estimating Run Times from Previously Established Run Conditions* (publication DS-719).

RUN SPEEDS



The centrifugal force at a given radius in a rotor is a function of speed. Comparisons of forces between different rotors are made by comparing the rotors' relative centrifugal fields (RCF). When rotational speed is adjusted so that identical samples are subjected to the same rcf in two different rotors, the samples are subjected to the same force. The RCF at a number of rotor speeds is provided in Table 4.

Do not select rotational speeds higher than the maximums you have determined to be appropriate for your protocols (in no case above 20 000 rpm). In addition, when centrifuging solutions more dense than 1.2 g/mL in this rotor, calculate the reduced maximum allowable rotor speed:

$$\text{reduced maximum speed} = (20\,000 \text{ rpm}) \sqrt{\frac{1.2 \text{ g/mL}}{\rho}} \quad (7)$$

where ρ is the density of the tube contents. *Note, however, that the use of this formula may still produce maximum speed figures higher than the limitations imposed by the use of certain tubes or adapters (see Table 3).* In such cases, use the lower of the two figures.

Table 4. Relative Centrifugal Fields for the JA-20 Rotor.
 Entries in this table are calculated from the formula
 $RCF = 1.12 r (RPM/1000)^2$
 and then rounded to three significant digits.

Rotor Speed (rpm)	Relative Centrifugal Field (× g)			Rotor Speed (rpm)	Relative Centrifugal Field (× g)		
	At r_{max} (108 mm)	At r_{av} (70 mm)	At r_{min} (32 mm)		At r_{max} (108 mm)	At r_{av} (70 mm)	At r_{min} (32 mm)
20 000	48 400	31 400	14 300	11 500	16 000	10 400	4 740
19 500	46 000	29 800	13 600	11 000	14 600	9 490	4 340
19 000	43 700	28 300	12 900	10 500	13 300	8 640	3 950
18 500	41 400	26 800	12 400	10 000	12 100	7 840	3 580
18 000	39 200	25 400	11 600	9 500	10 900	7 080	3 240
17 500	37 000	24 000	11 000	9 000	9 800	6 350	2 900
17 000	35 000	22 700	10 400	8 500	8 740	5 660	2 590
16 500	32 900	21 300	9 760	8 000	7 740	5 020	2 290
16 000	31 000	20 100	9 180	7 500	6 800	4 410	2 020
15 500	29 100	18 800	8 610	7 000	5 910	3 840	1 760
15 000	27 200	17 600	8 070	6 500	5 110	3 310	1 510
14 500	25 400	16 500	7 540	6 000	4 360	2 820	1 290
14 000	23 700	15 400	7 030	5 500	3 660	2 370	1 080
13 500	22 100	14 300	6 530	5 000	3 020	1 960	896
13 000	20 400	13 300	6 060	4 500	2 450	1 590	726
12 500	18 900	12 300	5 600	4 000	1 940	1 250	573
12 000	17 400	11 300	5 160	3 500	1 480	960	439

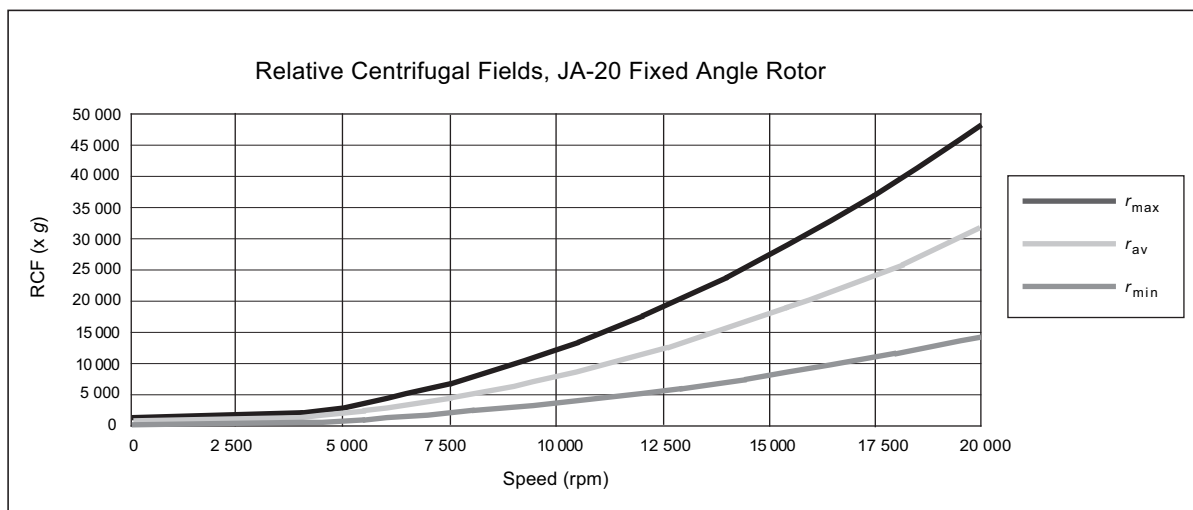

CARE AND MAINTENANCE

MAINTENANCE

NOTE

Do not use sharp tools on the rotor that could cause scratches in the rotor surface. Corrosion begins in scratches and may open fissures in the rotor with continued use.

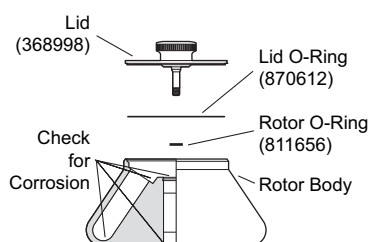

- Periodically (at least monthly) inspect the rotor, especially inside cavities, for rough spots or pitting, white powder deposits (frequently aluminum oxide), or heavy discoloration. If any of these signs are evident, do not run the rotor. Contact your Beckman Coulter representative for information about the Field Rotor Inspection Program and the rotor repair center.
- Before using the rotor, inspect the rotor drive pins to ensure that they are not damaged. Damaged drive pins can prevent the rotor from seating properly on the centrifuge drive hub (Avanti J series centrifuges only). To inspect the drive pins, turn the rotor upside down and look into the drive hole in the center of the rotor. If the drive pins appear damaged, contact Beckman Coulter Field Service.
- Routinely apply Spinkote lubricant (306812) to the centrifuge drive spindle hub to prevent the rotor from sticking (not required on Avanti J centrifuges).
- Regularly lubricate the metal threads in the rotor with a thin, even coat of Spinkote lubricant. Failure to keep these threads lubricated can result in damaged threads.
- Regularly apply silicone vacuum grease to the O-rings. Replace O-rings about twice a year or whenever worn or damaged.

Refer to Appendix A in *Rotors and Tubes* for chemical compatibilities of rotor and accessory materials. Your Beckman Coulter representative provides contact with the Field Rotor Inspection Program and the rotor repair center.

CLEANING

Wash the rotor and rotor components immediately if salts or other corrosive materials are used or if spillage has occurred. Do not allow corrosive materials to dry on the rotor.



Under normal use, wash the rotor frequently (at least weekly) to prevent buildup of residues.

1. Remove the O-rings before washing.
2. Wash the rotor and lid in a mild detergent, such as Beckman Solution 555, that won't damage the rotor. The Rotor Cleaning Kit (339558) contains two special plastic-coated brushes and two quarts of Solution 555 for use with rotors and accessories. Dilute the detergent 10 to 1 with water.

NOTE

Do not wash rotor components in a dishwasher.
Do not soak in detergent solution for long periods, such as overnight.

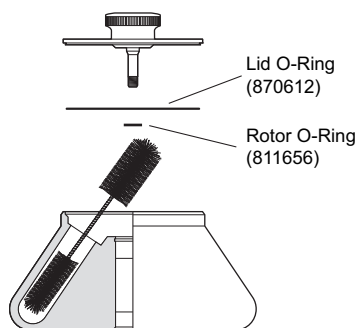

3. Thoroughly rinse the cleaned rotor and components with distilled water.
4. Air-dry the rotor and lid upside down. *Do not use acetone to dry the rotor.*
5. Apply a thin, even coat of silicone vacuum grease to the lid O-ring before replacing it in the groove in the outer rim of the lid. Also apply silicone vacuum grease to the rotor O-ring before reassembly.

Clean metal threads every 6 months, or as necessary. Use a brush and concentrated Solution 555. Rinse and dry thoroughly, then lubricate lightly but evenly with Spinkote to coat all threads.

Periodically remove the O-rings and wipe clean as necessary. Clean the O-ring grooves with a cotton-tipped swab. Reapply a light film of silicone vacuum grease.

DECONTAMINATION

If the rotor (and/or accessories) becomes contaminated with radioactive material, it should be decontaminated using a solution that will not damage the anodized surfaces. Beckman Coulter has tested a



number of solutions and found two that do not harm anodized aluminum: RadCon Surface Spray or IsoClean Solution (for soaking),³ and Radiacwash.⁴

NOTE

IsoClean can cause fading of colored anodized surfaces. Use it only when necessary and remove it promptly from surfaces.

While Beckman Coulter has tested these methods and found that they do not damage components, no guarantee of decontamination is expressed or implied. Consult your laboratory safety officer regarding the proper decontamination methods to use.



If the rotor or other components are contaminated with toxic or pathogenic materials, follow appropriate decontamination procedures as outlined by your laboratory safety officer.

STERILIZATION AND DISINFECTION

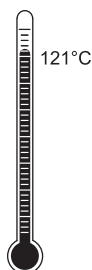

- The rotor and all rotor components can be autoclaved at 121°C for up to an hour. Remove the lid from the rotor and place the rotor and lid in the autoclave upside down.
- Ethanol (70%)⁵ may be used on all rotor components, including those made of plastic. Bleach (sodium hypochlorite) may be used, but may cause discoloration of anodized surfaces. Use the minimum immersion time for each solution, per laboratory standards.

While Beckman Coulter has tested these methods and found that they do not damage the rotor or components, no guarantee of sterility or disinfection is expressed or implied. When sterilization or disinfection is a concern, consult your laboratory safety officer regarding proper methods to use.

Refer to publication IN-192, included in each box of tubes or bottles, for tube and bottle sterilization and disinfection procedures.

³ In U.S., contact Nuclear Associates (New York); in Eastern Europe and Commonwealth States, contact Victoreen GmbH (Munich); in South Pacific, contact Gammasonics Pty. Ltd. (Australia); in Japan, contact Toyo Medic Co. Ltd. (Tokyo).

⁴ In U.S., contact Biodex Medical Systems (Shirley, New York); internationally, contact the U.S. office to find the dealer closest to you.

⁵ Flammability hazard. Do not use in or near operating centrifuges.

STORAGE

When the rotor is not in use, store it in a dry environment (not in the instrument) with the lid removed to allow air circulation so moisture will not collect in the tube cavities.

RETURNING A ROTOR

Before returning a rotor or accessory for any reason, prior permission (a Returned Goods Authorization form) must be obtained from Beckman Coulter, Inc. This RGA form may be obtained from your local Beckman Coulter sales office, and should contain the following information:

- serial number
- history of use (approximate frequency of use),
- reason for the return,
- original purchase order number, billing number, and shipping number, if possible,
- name and phone number of the person to be notified upon receipt of the rotor or accessory at the factory, and,
- name and phone number of the person to be notified about repair costs, etc.

To protect our personnel, it is the customer's responsibility to ensure that all parts are free from pathogens and/or radioactivity. Sterilization and decontamination must be done before returning the parts. Smaller items (such as tubes, bottles, etc.) should be enclosed in a sealed plastic bag.

*All parts must be accompanied by a note, plainly visible on the outside of the box or bag, stating that they are safe to handle and that they are not contaminated with pathogens or radioactivity. **Failure to attach this notification will result in return or disposal of the items without review of the reported problem.***

Use the address label printed on the RGA form when mailing the rotor and/or accessories.

Customers located outside the United States should contact their local Beckman Coulter office.

SUPPLY LIST

NOTE

Publications referenced in this manual can be obtained by calling Beckman Coulter at 1-800-742-2345 in the United States, or by contacting your local Beckman Coulter office.

Contact Beckman Coulter Sales (1-800-742-2345 in the United States) or your local Beckman Coulter office, or see the *High Performance, High Speed, High Capacity Rotors, Tubes & Accessories* catalog (BR-8102) for detailed information on ordering parts and supplies. For your convenience, a partial list is given below.

REPLACEMENT ROTOR PARTS

JA-20 rotor assembly	334831
Lid assembly	368998
Lid attachment bolt assembly	358305
O-ring (lid)	870612
O-ring (rotor)	811656
Tie-down kit	364914
Hold-down knob, for use with filtration tubes normally run without lid (J2/J6 series centrifuges only)	392889

OTHER

Tubes and bottles	see Table 3
Spinkote lubricant (2 oz)	306812
Silicone vacuum grease (1 oz)	335148
Rotor Cleaning Kit	339558
Beckman Solution 555 (1 qt)	339555
Rotor cleaning brush	339379
Rotor removal tool	338896
Collar adapter for rotor removal tool	338689

J SERIES ROTOR WARRANTY

Subject to the conditions specified below and the warranty clause of the Beckman Coulter, Inc., terms and conditions of sale in effect at the time of sale, Beckman Coulter, Inc. agrees to correct either by repair, or, at its election, by replacement, any defects of material or workmanship which develop within seven (7) years after delivery of a J series rotor to the original buyer by Beckman Coulter, Inc. or by an authorized representative, provided that investigation and factory inspection by Beckman Coulter, Inc. discloses that such defect developed under normal and proper use. Should a Beckman Coulter centrifuge be damaged due to a failure of a rotor covered by this warranty, Beckman Coulter will supply free of charge all centrifuge parts required for repair.

REPLACEMENT

Any product claimed to be defective must, if requested by Beckman Coulter, Inc., be returned to the factory, transportation charges prepaid, and will be returned to Buyer with the transportation charges collect unless the product is found to be defective, in which case Beckman Coulter, Inc. will pay all transportation charges.

A defective rotor will be replaced by Beckman Coulter, Inc. at its then current list price less a credit based upon the age of the rotor (years since date of purchase). The Buyer shall not receive credit until the claimed defective rotor is returned to Beckman Coulter's Indianapolis, Indiana facility or delivered to a Beckman Field Service representative.

The replacement price (cost to Buyer) for the respective rotor shall be calculated as follows:

$$\text{Replacement price} = \text{Current rotor list price} \times \frac{\text{years}}{7}$$

CONDITIONS

1. Except as otherwise specifically provided herein, this warranty covers the rotor only and Beckman Coulter, Inc. shall not be liable for damage to accessories or ancillary supplies including but not limited to (i) tubes, (ii) tube caps, (iii) tube adapters, or (iv) tube contents.
2. This warranty is void if the rotor has been subjected to customer misuse such as operation or maintenance contrary to the instructions in the Beckman Coulter rotor or centrifuge manual.
3. This warranty is void if the rotor is operated with a rotor drive unit or in a centrifuge unmatched to the rotor characteristics, or is operated in a Beckman Coulter centrifuge that has been improperly disassembled, repaired, or modified.

DISCLAIMER

IT IS EXPRESSLY AGREED THAT THE ABOVE WARRANTY SHALL BE IN LIEU OF ALL WARRANTIES OF FITNESS AND OF THE WARRANTY OF MERCHANTABILITY AND THAT BECKMAN COULTER, INC. SHALL HAVE NO LIABILITY FOR SPECIAL OR CONSEQUENTIAL DAMAGES OF ANY KIND WHATSOEVER ARISING OUT OF THE MANUFACTURE, USE, SALE, HANDLING, REPAIR, MAINTENANCE, OR REPLACEMENT OF THE PRODUCT.



Beckman Coulter, Inc. • 250 S. Kraemer Blvd. • Brea, California 92821 U.S.A.
Sales and Service: 1-800-742-2345 • Internet: www.beckmancoulter.com • Printed in U.S.A.

©2015 Beckman Coulter, Inc.
All rights reserved